

## The Harman Accentra-2 Pellet Stove

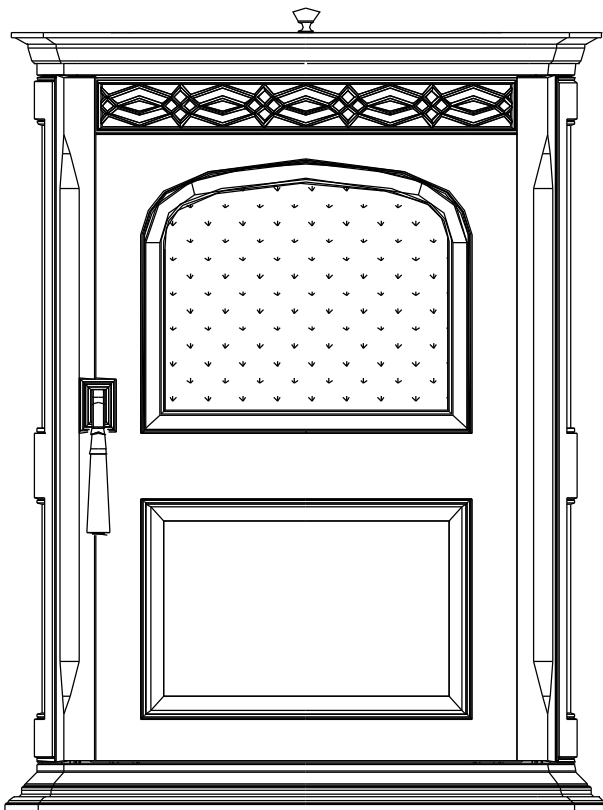

*"Ce manuel est disponible en Français sur demande"*

R4

### **SAFETY NOTICE**

PLEASE READ THIS ENTIRE MANUAL BEFORE YOU INSTALL AND USE YOUR NEW ROOM HEATER. FAILURE TO FOLLOW INSTRUCTIONS MAY RESULT IN PROPERTY DAMAGE, BODILY INJURY, OR EVEN DEATH.

FOR USE IN THE U.S. AND CANADA. SUITABLE FOR INSTALLATION IN MOBILE HOMES

IF THIS HARMAN ACCENTRA PELLET STOVE IS NOT PROPERLY INSTALLED, A HOUSEFIRE MAY RESULT. FOR YOUR SAFETY, FOLLOW INSTALLATION DIRECTIONS.

CONTACT LOCAL BUILDING OR FIRE OFFICIALS ABOUT RESTRICTIONS AND INSTALLATION INSPECTION REQUIREMENTS IN YOUR AREA.

CONTACT YOUR LOCAL AUTHORITY (SUCH AS MUNICIPAL BUILDING DEPARTMENT, FIRE DEPARTMENT, FIRE PREVENTION BUREAU, ETC.) TO DETERMINE THE NEED FOR A PERMIT.

CETTE GUIDE D'UTILISATION EST DISPONIBLE EN FRANCAIS. CHEZ VOTRE CONCESSIONNAIRE DE HARMAN STOVE COMPANY.

**SAVE THESE INSTRUCTIONS.**

This heating appliance does not just have automatic ignition, it has total automatic temperature control. The Accentra has an input heat range from 0 to 40,000 BTU's. This patented feed system has a maximum feed rate of 5 lbs. per hour and a minimum (maintenance) feed rate of .75 lbs. per hour and then "off" if necessary. The hopper holds approximately 50 pounds of fuel. The unit has an easy to clean combustion system with an ash pan that holds ash from 1 ton of burned premium pellets.

The control is designed for easy and efficient operation. It has 2 automatic modes of operation and 2 manual modes of operation.

The Accentra uses a small room sensor rather than a wall thermostat for a more accurate temperature control. This unit is equipped with several different safety devices which will be explained later in this manual. With its specially designed burn pot and the "Advance Ignitor" Automatic Ignition System, the unit can burn a large variety of biomass fuels with varying ash content. The accordian style cast iron heat exchanger system allows maximum surface area for the most efficient heat transfer in a smaller firebox.

Please copy your serial number from the label on your stove to the box below.

**SERIAL NUMBER**



**SAFETY NOTICE: IF THIS HARMAN ACCENTRA PELLET STOVE IS NOT PROPERLY INSTALLED. A HOUSE FIRE MAY RESULT. FOR YOUR SAFETY, FOLLOW THE INSTALLATION DIRECTIONS CONTACT LOCAL BUILDING OR FIRE OFFICIALS ABOUT RESTRICTIONS AND INSTALLATION INSPECTION REQUIREMENTS IN YOUR AREA.**

*Safety testing by Omni Testing Laboratory  
ASTM-E1509 • ULC-C1482 • Oregon-814-23-900  
per 40CFR-60.530 sup. part AAA  
per EPA method 28A and 5G*

**Harman Stove Company**  
352 Mountain House Road  
Halifax, PA 17032  
[sales@harmanstoves.com](mailto:sales@harmanstoves.com)

## Table of Contents

<b>Automatic Operation</b>	<b>4</b>
<b>Manual Operation</b>	<b>6</b>
<b>ESP Control</b>	<b>8</b>
<b>Assembly &amp; Installation</b>	<b>9</b>
<b>Venting</b>	<b>14</b>
<b>Maintenance</b>	<b>20</b>
<b>Trouble-Shooting</b>	<b>25</b>
<b>Specifications</b>	<b>26</b>
<b>Wiring Diagram</b>	<b>27</b>
<b>Feeder Parts</b>	<b>28</b>
<b>Parts List</b>	<b>29</b>
<b>Warranty</b>	<b>30</b>

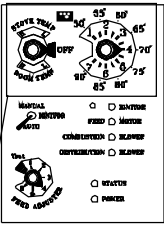

The Accentra pellet stove is more than just automatic ignition, it is also automatic temperature control. The automatic system will allow the fire size to be adjusted to match the heating needs and even put the fire out if necessary. If heat is needed after the fire is out, the Accentra will automatically re-ignite and adjust the fire size to match the heating need. The totally automatic room sensor mode is recommended because of its efficiency. The unit can be switched between "AUTO" and "MANUAL" at any time during operation.

## Igniter switch to "AUTO" Room Temperature Mode

In "Room Temp Mode" heat output is controlled automatically by the Room Sensing Probe. When the Room Sensing Probe calls for heat, the stove will increase output. When the Room Sensing Probe is getting close to the set temperature, the stove will begin to level off output and keep the fire burning at just the right temperature to maintain that setting.

High output is determined by the feed rate setting. This setting, generally on #4, can be increased if higher burn rates are necessary (Fig. 1). The unit's maximum burn rate should not create less than 1" of ash on the burn pot front edge (See Fig.4). Overfeeding is not a safety concern, but fuel may be wasted if unburned pellets fall into the ash pan.

In "Room Temp Mode" a constant fuel consumption rate is sacrificed for exact room temperature. Therefore, as it gets colder more pellets will be burned automatically.

The distribution blower speed will vary according to the position of the mode selector pointer, and fire size.

## Igniter switch to "AUTO" Stove Temperature Mode

This allows for automatic ignition upon start-up only. The unit can then be set at any desired setting. The heat output and fuel consumption will remain constant regardless of room temperature (See Fig 2). The unit's maximum feed rate should not create less than 1" of ash on the burn pot front edge. See Fig 4.

The unit's low burn or maintenance setting is as low as it will go. It will not go out unless it runs out of fuel or is turned off.

## Shut-Down Procedure

To kill the fire or stop burning the stove, turn the Mode Selector to "OFF". This will cause the fire to diminish and burn out. When the fire burns out and the stove cools down everything will stop.

If you pull the plug to shut down the stove, all motors will stop. This may cause incomplete combustion and smoke in the firebox. If the load door is opened the smoke may escape.

The best way to shut down the stove is simply let it run out of pellets, then the stove will shut down automatically.

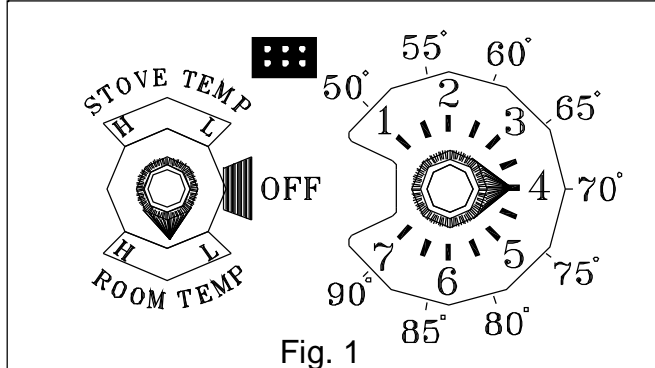
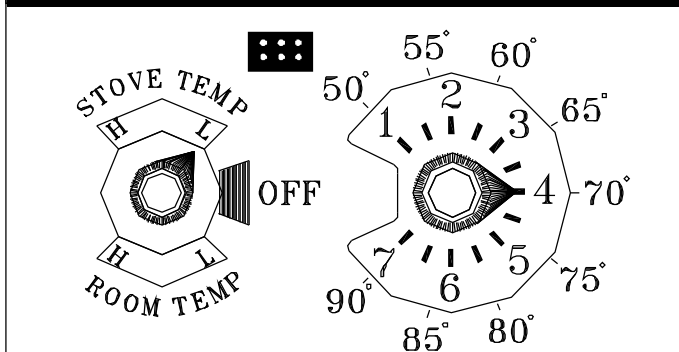

Fig. 1

**Room Temperature Mode:** This setting will produce a room temperature of 70 degrees with the distribution blower at medium speed.

## Stove Temperature Mode



This setting will produce medium heat with the distribution blower on "low".

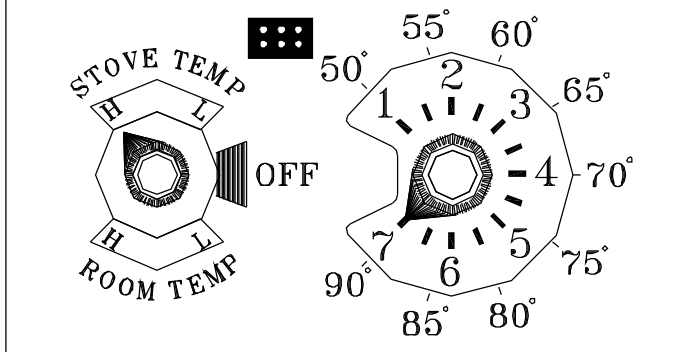

This setting will produce continuous maximum heat output with the distribution blower at full speed.

Fig. 2

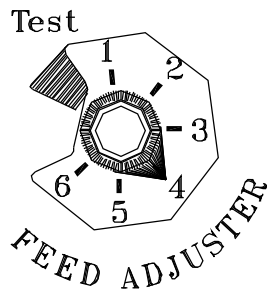

Fig. 3

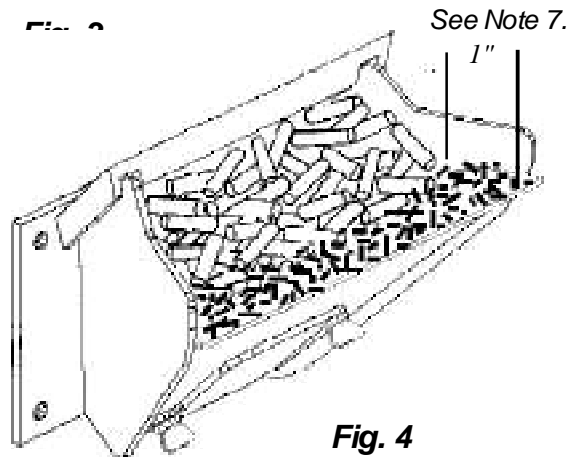

Fig. 4

1. Fines are small pieces or broken pellets (sawdust). Fines do not flow easily and often build up on the hopper funnel bottom angles. These fines can be pushed into the feeder opening and then fill the hopper with pellets. As the system works, they will be burned.
2. The "TEST" cycle will operate the feeder motor for exactly one minute. Turning to "TEST" again and again may purge too much fuel into the burn pot causing excessive smoke on start-up.
3. The firebox low pressure switch will not allow the auger motor or the igniter element to operate if the view door is open.
4. Adjust Feed Rate. If this is your first fire or you are trying different pellets, set the feed adjuster to #4, Fig. 3. This is a conservative number and will probably need to be increased. After you know a feed rate setting that works well, use that setting. Remember, if your feed rate is too high you may waste fuel.
5. This is usually a weekly maintenance procedure. Cleaning the burn pot with the scraper with a small amount of new fuel in the bottom is not a problem. First, scrape the ashes on the front of the burn pot into the ash pan. Then scrape the holed surface downward into the burn pot. When the stove is ignited these scrapings will be pushed out by the feeder.
6. The ash pan can hold the ashes from approximately 1 ton of premium fuel. This means the ashes will only need to be emptied a few times a year.
7. Setting the feed adjuster # for maximum burn: With the unit burning in "AUTO", turn to "Stove Mode" and put the fan on "H". Set the Temperature Dial to #7. Allow the unit to burn for about 30 minutes and check ash on front of burn pot. Fig. 4. If the ash line is larger than 1", turn the feed adjuster from #4 to #5. Allow another 30 minutes of burn time and check again. If, at #6 setting, a 1" or less ash bed is not obtainable, it is not a problem. The 1" ash bed is only a maximum burn rate and at most normal settings the ash bed will be larger.

## Starting First Fire

### Ignitor Switch to "AUTO" (down position)

Make sure the unit is plugged into a 120 VAC, 60 HZ electrical source. The power light should be the only light lit.

1. Turn Mode Selector to "OFF".
2. Fill hopper with pellets.<sup>1</sup>
3. Clean burn pot with scraper, if necessary.<sup>5</sup>
4. If starting after an empty hopper, turn Feed Adjuster to "TEST" (for one 60 second cycle).<sup>2</sup> This will purge pellets into the auger tube and also allow you to check the motors for operation. **NOTE: The auger motor will not operate with the view door or ash pan door open.**<sup>3</sup>
5. Turn Feed Adjuster to #4.<sup>4</sup>
6. Flip the Ignitor Switch down into the "AUTO" position.
7. Turn the Temperature Dial to desired room temperature.
8. Turn Mode Selector to Room Temperature or Stove Temperature.
9. Fill hopper with pellets and remove ashes as required.<sup>6</sup>

### Notice when using Optional Battery Back-Up

If a power outage is expected, change the toggle switch to Manual Mode. The Harman 502H Battery Backup is incapable of powering the igniter. If an automatic ignition is attempted while the stove is being powered by the battery back up, it may cause damage to both the stove and the battery backup unit.

## Warning

**NEVER USE GASOLINE, GASOLINE-TYPE LANTERN FUEL, KEROSENE, CHARCOAL LIGHTER FLUID, OR SIMILAR LIQUIDS TO START OR 'FRESHEN UP' A FIRE IN THIS HEATER. KEEP ALL SUCH LIQUIDS WELL AWAY FROM THE HEATER WHILE IN USE.**

The Accentra Pellet Stove is capable of manual operation. This also allows the operator to manually control operation during an emergency (i.e. igniter failure, when using a 502H battery backup, or when using certain generators.)

The unit can be switched between "AUTO" and "MANUAL" at any time during operation.

**NOTE: When starting the unit in the "AUTO" mode and switching to "MANUAL", the fire must be large enough to start the distribution blower. The starting of the blower is a signal that the start cycle is completed and the fire will not go out.**

**Ignitor Switch to "MANUAL"**  
**Room Temperature Mode**

The fire will have to be lit with starting gel and a match, or started automatically, see "Automatic Operation". Turn to "Manual" position when the fire is established.

The difference between "AUTO" Room Temperature Mode and "Manual" Room Temperature Mode is that the fire will not go out as the room temperature goes above the control board setting. The unit can only go to low burn and will remain there until it runs out of fuel or until more heat is needed and the feed rate increases. Feed rate adjustments and dial settings are the same as "AUTO" settings.

**Ignitor Switch to "MANUAL"**  
**Stove Temperature Mode**

The advantage of this mode is to allow the operator to have a large viewing fire without blowing extra heat into the room.

During operation, with the temperature dial set at #5 or less, the distribution fan will not operate. A #5 on the temperature dial and a #5 on the feed adjuster is approximately 80% output. It is not necessary to operate the distribution blower below this point. Therefore, there can be a higher feed rate ( a larger viewing fire) without an excess of hot air blowing into the room.

An example of when to use the Manual Stove Temperature Mode is if you want to watch a large fire and the room is already up to temperature. The Stove Temperature Mode allows you to have a larger fire and a lower sound level, without the distribution blower.

**NOTE: During the use of this mode, if you keep increasing the temperature dial setting to increase the fire size, the distribution blower will automatically come on when the ESP Temperature reaches 350° F, or 81% output.**

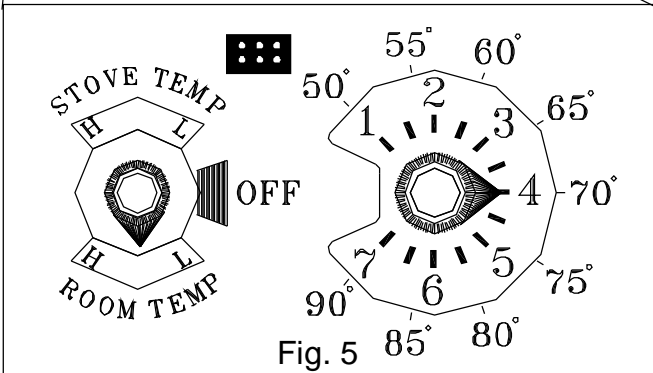
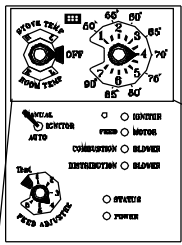

**Room Temperature Mode:** This setting will produce a room temperature of 70 degrees with the distribution blower at medium speed.

**Manual Stove Temperature Mode**

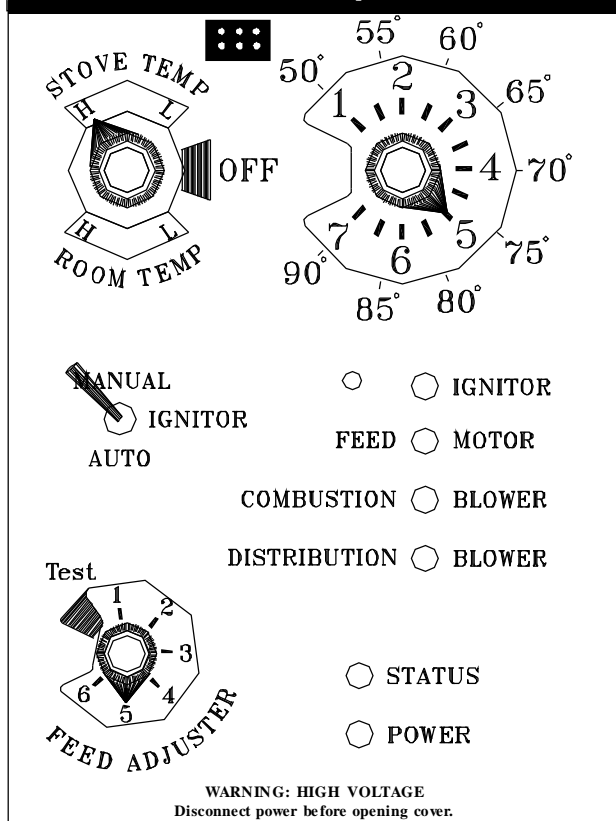

This setting will produce a large viewing fire without a distribution blower operating.

Fig. 6

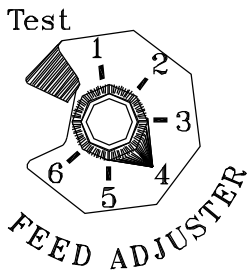

Fig. 7

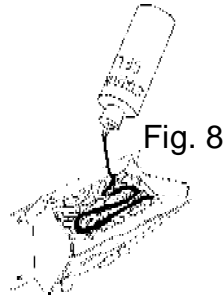

Fig. 8

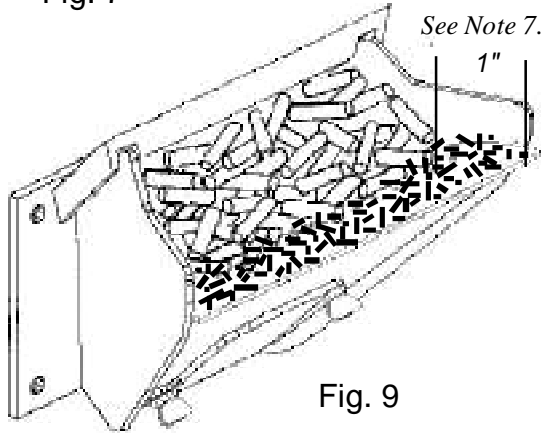

Fig. 9

1. Fines are small pieces of broken pellets (sawdust). Fines do not flow easily and often build up on the hopper funnel bottom angles. These fines can be pushed into the feeder opening and then fill the hopper with pellets. As the system works, they will be burned.

2. The "TEST" cycle will operate the feeder motor for exactly one minute. Turning to "TEST" again and again may purge too much fuel into the burn pot causing excessive smoke on start-up.

3. The firebox low pressure switch will not allow the auger motor or the igniter element to operate if the view door or the ash pan door are open.

4. Adjust Feed Rate. If this is your first fire or you are trying different pellets, set the feed adjuster to #4, Fig. 7. This is a conservative number and will probably need to be increased. After you know a feed rate setting that works well, use that setting. Remember, if your feed rate is too high you may waste fuel.

5. This is usually a weekly maintenance procedure. Cleaning the burn pot with the scraper with a small amount of new fuel in the bottom is not a problem. First, scrape the ashes on the front of the burn pot into the ash pan. Then scrape the holed surface downward into the burn pot. When the stove is ignited these scrapings will be pushed out by the feeder.

6. The ash pan can hold the ashes from approximately 1 ton of premium fuel. This means the ashes will only need to be emptied a few times a year.

7. Setting the feed adjuster # for maximum burn: With the unit burning in "AUTO", turn to "Stove Mode" and put the fan on "H". Set the Temperature Dial to #7. Allow the unit to burn for about 30 minutes and check ash on front of burn pot. Fig. 9. If the ash line is larger than 1", turn the feed adjuster from #4 to #5. Allow another 30 minutes of burn time and check again. If, at #6 setting, a 1" or less ash bed is not obtainable, it is not a problem. The 1" ash bed is only a maximum burn rate and at most normal settings the ash bed will be larger.

## Starting First Fire

### Ignitor Switch to "MANUAL" (up position)

Make sure the unit is plugged into a 120 VAC, 60 HZ electrical source. The power light should be the only light lit.

1. Turn **FEED ADJUSTER** to desired feed rate. No. 4 is good for most pellets.<sup>4</sup>
2. Turn the **MODE SELECTOR** to "OFF" and then to the desired mode. This will reset control and start the combustion motor.
3. Turn the **TEMPERATURE DIAL** to the desired setting.
4. Clean burn pot with scraper if necessary.<sup>5</sup>
5. Fill burn pot with pellets, only level with front edge. (Do Not Over Fill).
6. Add starting gel on top of the pellets. Stir gel into pellets for fast lighting.
7. Light starting gel with a match, and close the door. Operation will begin when the fire reaches the proper temperature.<sup>3</sup>
8. Fill hopper with pellets and remove ashes as required.<sup>1, 6</sup>

### Notice when using Optional Battery Back-Up:

If a power outage is expected, change the toggle switch to Manual Mode. The Harman 502H Battery Backup is incapable of powering the igniter. If an automatic ignition is attempted while the stoves is being powered by the battery back up, it may cause damage to both the stove and the battery backup unit.

## Warning

**NEVER USE GASOLINE, GASOLINE-TYPE LANTERN FUEL, KEROSENE, CHARCOAL LIGHTER FLUID, OR SIMILAR LIQUIDS TO START OR 'FRESHEN UP' A FIRE IN THIS HEATER. KEEP ALL SUCH LIQUIDS WELL AWAY FROM THE HEATER WHILE IN USE.**

### Mode Selector

Allows you to choose between Room Temp Mode, Stove Temp Mode, or OFF. Also allows you to vary the distribution blower speed by turning the knob to the high or low side of each mode.

**Distribution Blower speed adjustment range.**  
L=low  
H=high  
Variable speed anywhere between L and H; although as the stove temp. goes up, so does the L and H scale.

### Igniter switch

Set to appropriate Start-Up mode.

### Test

Runs all motors at full speed for one minute to check operation. After two minutes the stove will go to minimum burn and the blowers will alternate from high to low every minute to remind you that you are still in "Test Mode".

### Feed adjuster

Sets the maximum feed rate

### Dealer Diagnostic Port

For dealer maintenance only. Requires special DDM monitor supplied to Harman Dealers exclusively.

### Temp dial

Allows you to adjust the room temperature in Room Temp Mode using the outer scale marked in degrees Fahrenheit. It also allows you to adjust the stove temperature while in Stove Temp Mode using the inner scale marked from 1 to 7.

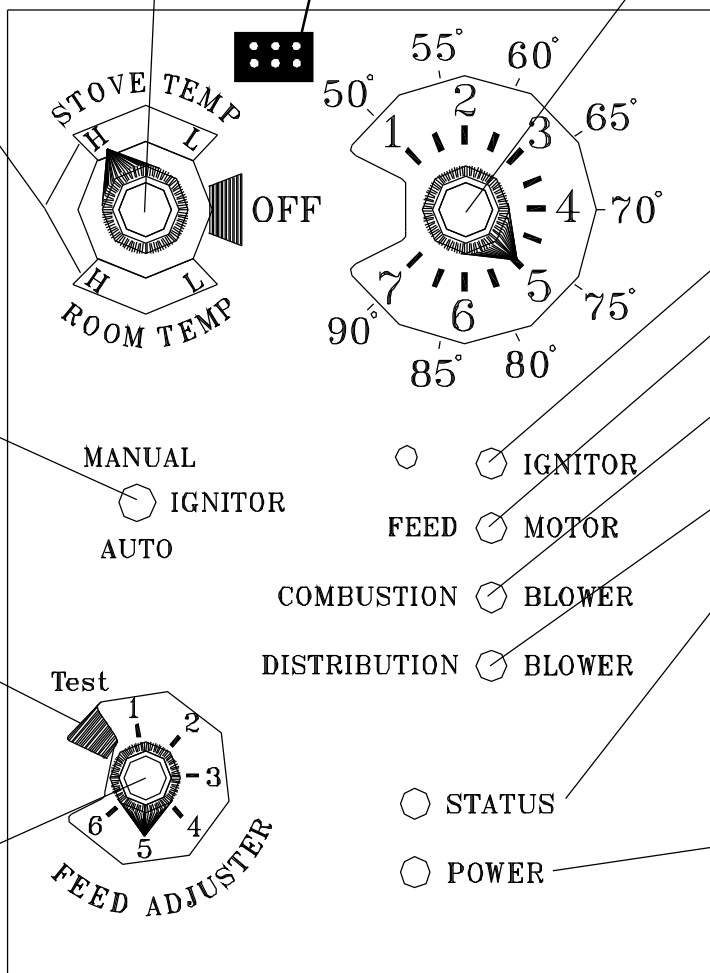

Indicates igniter is on.

Indicates power to the feed motor.

Indicates power to combustion blower

Indicates power to distribution blower.

### Status Light

Will be lit in either stove or room temp mode when pointer is not within off position band except after normal shut down. Blinks to indicate errors listed below.

### Power Light

Indicates power to the control.

## Status light error messages:

**1 Blink:** Indicates control board self diagnostic failure. This requires a manual reset\*.

**3 Blinks:** Indicates ESP (Exhaust Sensing Probe) failure. This requires a manual reset\*.

**4 Blinks:** Can occur only in Room Temp Mode and indicates Room Sensing Probe failed or not installed. If a Room Sensing Probe is then installed, the status light will automatically reset.

NOTE: Unit will not start in "AUTO" with this status error.

**5 Blinks (In Igniter Auto. Mode Only):** Indicates that the unit has failed to light within the 36 minute start cycle. To reset - Turn Mode Selector to "OFF", then turn to either mode again.)

**6 Blinks :** Indicates that the control has calculated poor or incomplete combustion occurring for more than 50 minutes.

A six blink status may be set if the stove is allowed to run out of pellets. To reset, turn mode selector to "OFF" then back on to the desired mode. If the unit was not out of pellets, see Troubleshooting section, Page 24, for more details.

\* **Manual reset-** disconnect power cord for a few seconds and reconnect. If error still occurs call your Dealer.

When installing and operating your Harman Accentra Pellet Stove, respect basic safety standards. Read these instructions carefully before you attempt to install or operate the Accentra. Failure to do so may result in damage to property or personal injury and may void the product warranty.

Consult with your local building code agency and insurance representative before you begin your installation to ensure compliance with local codes, including the need for permits and follow-up inspections.

Several issues must be addressed when selecting a suitable location for your Accentra Pellet Stove. Observing required clearances to combustible materials, the proximity to a safe chimney or venting system, and the accessibility of electrical supply must all be considered. In addition, selecting a location that takes advantage of the building's natural air flow is also desirable to maximize the heating effectiveness of the heater. In many cases, this is a central location within the building.

Adequate combustion and ventilation air must be provided. The Accentra pellet stove is capable of being installed with a 100% outside air combustion system. See Page 14 about venting.

Place the stove on a noncombustible floor surface. If the floor surface is made of a combustible material, (such as carpet, vinyl or wood), a noncombustible material must be installed between the bottom of the unit and the floor. This can be a minimum of a 20 gauge sheetmetal plate, ceramic tile with grouted joints, a UL listed stove board, or a Harman Cast Iron floor protector<sup>1</sup>. The Harman Cast Iron Floor Protector is equal to the minimum dimensions, which are  $24\frac{1}{16} \times 28\frac{5}{8}$ . This allows for a 2" extension on each side of the unit and a 6" extension to the front of the ash opening ( $3\frac{3}{8}$ " if measured from the base plate front edge.) The rear edge of the floor protection can be flush with the cast base plate rear edge.

Place the stove away from combustible walls at least as far as shown in figures 10, 11, 12, & 13

Note that the clearances shown are minimum for safety but do not leave much room for access when cleaning or service is needed.

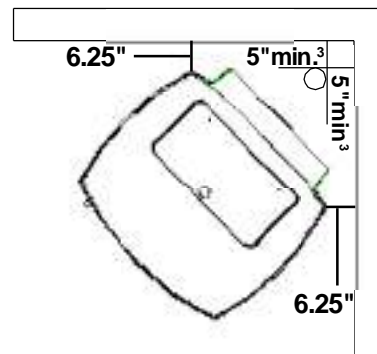

Fig.10

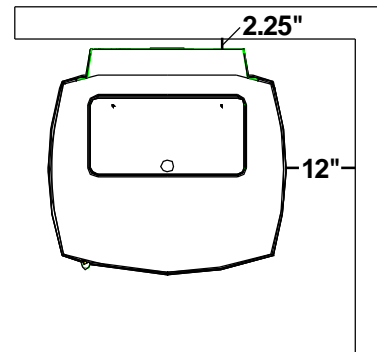

Fig.11

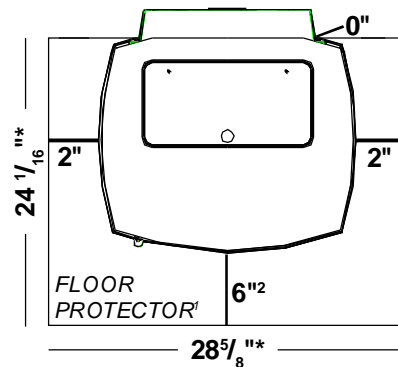

Fig.12

(\*Harman Cast Iron Floor Protector size)

*This is the minimum size Harman recommends for the alcove with a 60" ceiling.*

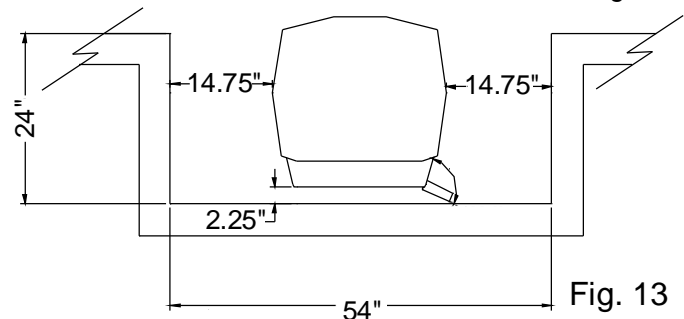

Fig. 13

## AFTER THE INSTALLATION IS COMPLETED

Before the first fire is lit, check and record the high and low draft reading numbers on page 12. Make adjustments to the low draft at this time, if necessary.

## CAUTION

The stove is hot while in operation.  
Keep children, clothing and furniture away.  
Contact may cause skin burns.

1. Check your local codes to see if protection is required under the flue pipe.
2. This measurement equals 6" from inside edge of ash door opening.
3. 5" pipe clearance to wall in a corner installation.



**IMPORTANT NOTE:** The Accentra unit is shipped bolted to the skid through two holes in the cast base plate. If these holes are not used to lag the unit to the floor these holes must be filled with the 3/8" x 1/2" hex head bolts provided. (See tag on bolt bag provided.)

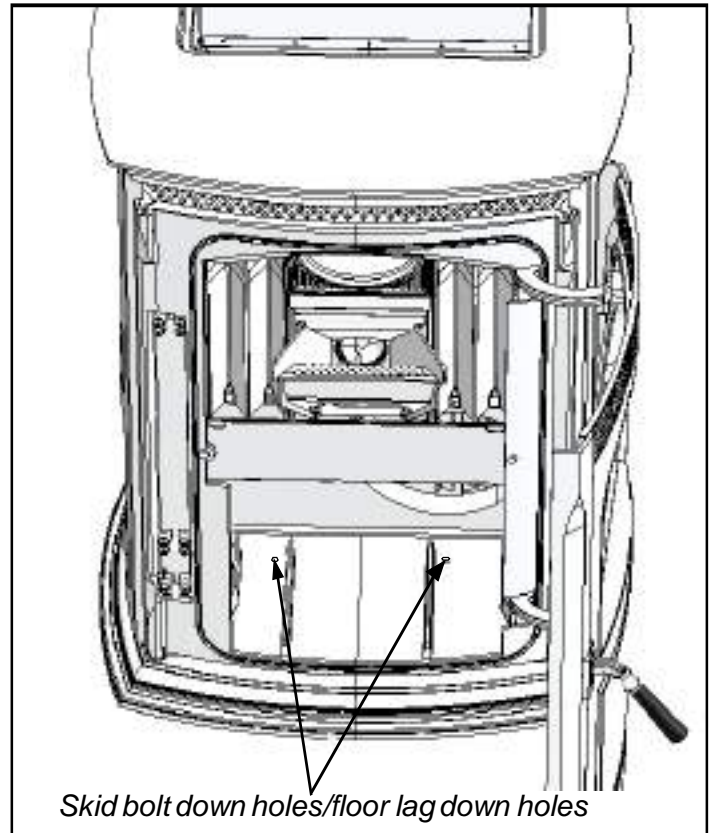

Fig. 14

### Adjustment of the rubber pad leveling feet

The Accentra is provided with 4 rubber pad feet. These feet will raise the bottom edge of the cast base plate off the floor surface. This will insure that any vibrations caused by motors and other moving parts will not be transferred by direct contact. These rubber pads have a threaded stud that extends through the base plate. The top of the threaded stud has a screwdriver slot. Therefore, the unit can be leveled from above inside the unit. The front two are in the right and left front corners of the firebox. NOTE: The door will need to be partially closed to access the right leveling pad stud due to the door hinge.

The rear two studs are to the right and left of the distribution blower. They are somewhat difficult to reach, therefore, it is suggested that the rear two pads be adjusted by tilting the unit slightly forward. Adjust the pads with your fingers and tilt unit back for fit. Then adjust the front pads for the final clearance. (The use of the rubber pads is not necessary if not desired.)

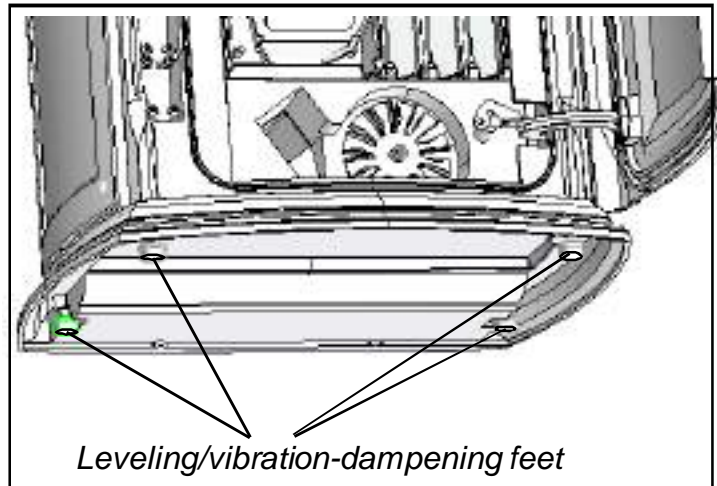

Fig. 15

When installing the Accentra in a mobile home several requirements must be followed:

1. The unit must be bolted to the floor. This can be done with 1/4" lag screws through the 2 holes in the base plate shown in Fig. 16
2. The unit must also be connected for the outside air. See page 14.
3. Floor protection and clearances must be followed as shown on page 9.
4. Unit must be grounded to the metal frame of the mobile home.

**CAUTION: This appliance must be vented to the outside.**

Due to high temperatures, the Accentra should be placed out of traffic and away from furniture and draperies.

Children and adults should be alerted to the hazards of high surface temperatures and should stay away to avoid burn to skin and/or clothing.

Young children should be carefully supervised when they are in the same room as the stove.

Clothing and other flammable materials should not be placed on or near the Accentra Pellet Stove.

Installation and repair of the Accentra Pellet Stove should be done by a qualified service person. The appliance should be inspected before use and at least annually by a qualified service person. More frequent cleaning will be required. It is imperative that control compartments, burners, and circulating air passageways of the Accentra be kept clean.

**Mobile home installation should be done in accordance with the Manufactured Home and Safety Standard (HUD), CFR 3280, Part 24.**

**AFTER THE INSTALLATION IS COMPLETED**

Before the first fire is lit, check and record the high and low draft reading numbers on page 12. Make adjustments to the low draft at this time, if necessary.

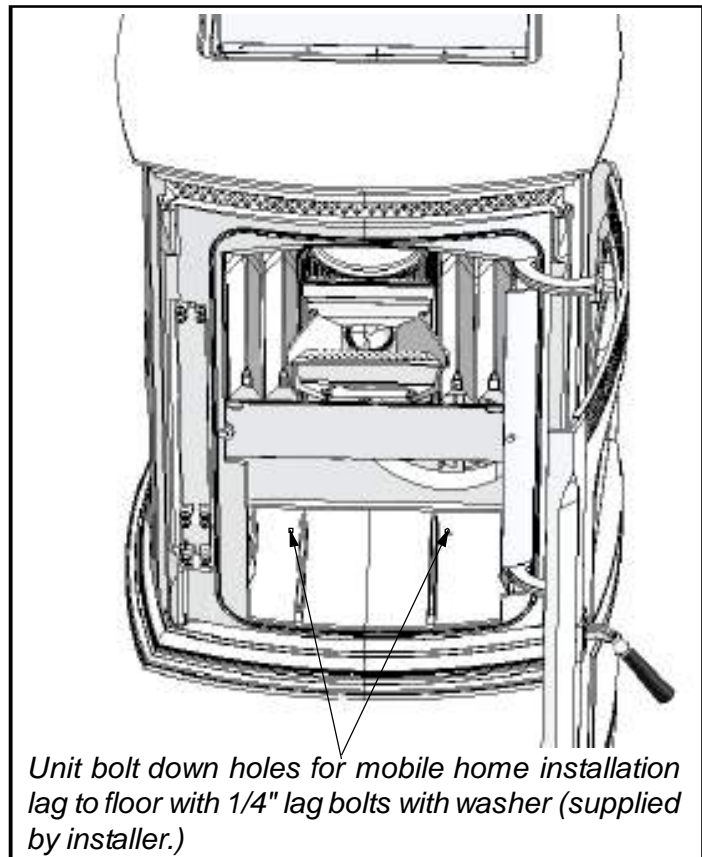

*Unit bolt down holes for mobile home installation lag to floor with 1/4" lag bolts with washer (supplied by installer.)*

Fig. 16

**CAUTION**

**THE STRUCTURAL INTEGRITY OF THE MOBILE HOME FLOOR, WALL, AND CEILING/ROOF MUST BE MAINTAINED.**

**CAUTION**

**THE STOVE IS HOT WHILE IN OPERATION. KEEP CHILDREN, CLOTHING AND FURNITURE AWAY. CONTACT MAY CAUSE SKIN BURNS.**

**WARNING**

**KEEP COMBUSTIBLE MATERIALS SUCH AS GRASS, LEAVES, ETC. AT LEAST 3 FEET AWAY FROM THE POINT DIRECTLY UNDER THE VENT TERMINATION.**

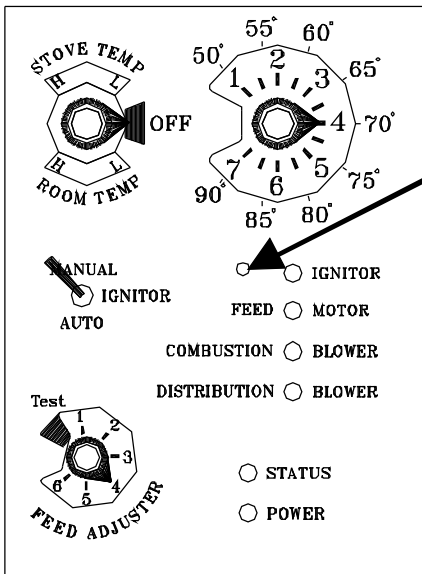

Fig.17

**Combustion Motor Speed Control**  
**Low draft only set point.**  
*The small straight screwdriver slot is plastic; therefore, the unit can be adjusted while in operation.*

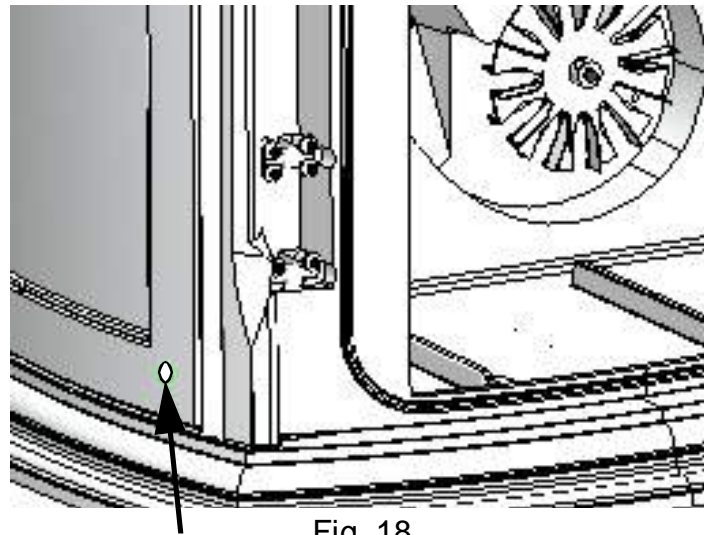

Fig. 18

Draft Meter bolt hole location

These units are pre-tested at the factory with exactly 120 Volts A.C., 60 Hz. They are checked and adjusted for firebox tightness, gasket leakage, motor operation and ignitor operation. The Accentra is then factory set at a high adjustment. **NOTE: Low draft adjustment may be required. The factory low draft setting may not be correct for the units permanent installation conditions.**

The control board on the Accentra is equipped with a low draft adjustment port. Located on the control face just to the left of the ignitor light. See Figure 17. This voltage adjustment is provided to allow the unit to be adjusted for the household voltage where the unit is going to be in permanent operation. **NOTE:** The line voltage varies from area to area and often home to home.

The low draft voltage should be adjusted to achieve the most efficient burn on low burn or "maintenance". This voltage adjustment allows the installer to change the low voltage set point approximately 15 volts. This adjustment should be done by the installer during set up because a draft meter reading is **required** to insure proper set up.

If the unit is not adjusted properly, it does not cause a safety concern. If the unit is adjusted too high, only efficiency is lost. If the unit is adjusted too low, the low draft pressure switch will not allow the feeder motor or the ignitor to operate.

A simple draft test should be performed after completing the flue pipe installation. To record the results for future reference:

1. Plug unit into a 120VAC, 60 HZ outlet.
2. Close the hopper lid and front view door. Neither pellets or a fire are required for this test.
3. With the mode selector in the "OFF" position, turn the feed adjuster to "TEST".
4. Record the high draft \_\_\_\_\_ in. W.C. (Normal is - .45 to - .55) The control will be on the High Draft for a total of 2 minutes.
5. After 2 minutes is up, the combustion motor will go down to low draft and the distribution blower will go on high. Allow approximately 15 seconds to pass for the combustion motor to slow before checking the low draft.
6. If the low draft is between .30 and .35, record the reading \_\_\_\_\_ in. W.C. If the reading is higher, slowly turn the set screw counter-clockwise until the draft lowers. If the reading is lower, very slowly turn the set screw clockwise until the draft increases.

**NOTE: The test mode alternates from high to low draft every 60 seconds. If more time is needed for draft adjustment, wait until the next low draft cycle.**

**NOTE: In some cases, the draft may not go as low as .30 even with the set screw completely counter-clockwise.**

## Room Sensor Installation



Fig. 19

The room sensor is a small temperature sensor on the end of a 60" gray wire. This sensor is installed much like a standard wall thermostat. Because it is so small, it can be hidden along the trim of a doorway or even up the leg of a coffee table. There is a remote room sensor port on the rear of the unit for easy external connection. Use standard 18-2 thermostat wire to extend the distance to the desired location (100' maximum). The room sensor should be installed in the location where you want to control the temperature.

NOTE: Distances of more than 25 feet from the unit or in another room are not recommended. The room sensor is essential for the Accentra's excellent efficiency.

**It is recommended that the room sensor be installed,** even if only installed on the rear of the unit as a return air sensor. There is an intake screen on the bottom of the rear sheetmetal enclosure. This is an ideal place to tyrap the sensor head to sense return air temperature.

## Rear Shields

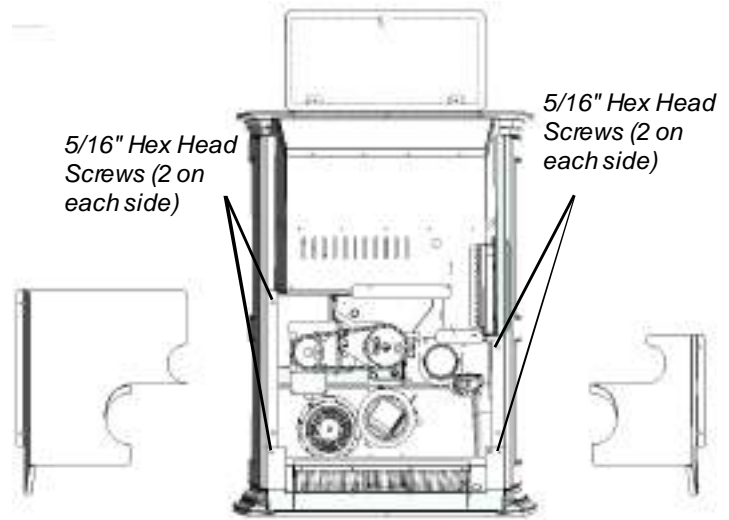

Fig. 20

The rear isolated shields are split in the middle for easy removal. Each shield has two 5/16" hex head screws that only need to be loosened (NOT REMOVED) to allow the shield to slide away from the unit. **NOTE: It is not recommended that the unit be operated with the shields removed, due to the hot and moving parts which they protect.**

## REMINDERS

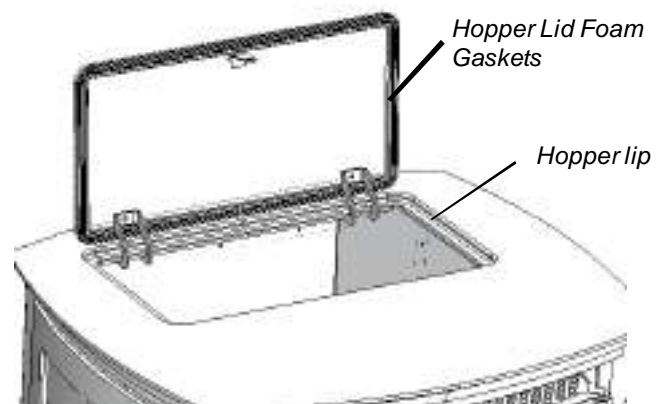

Fig. 21

Do not allow pellets or sawdust to build up on the hopper lip.

Inspect the hopper lid gasket for damage. A good hopper lid seal is very important for proper operation.

## **IMPORTANT NOTICE**

Pellet Vent Pipe or PL Vent Pipe Must be used.

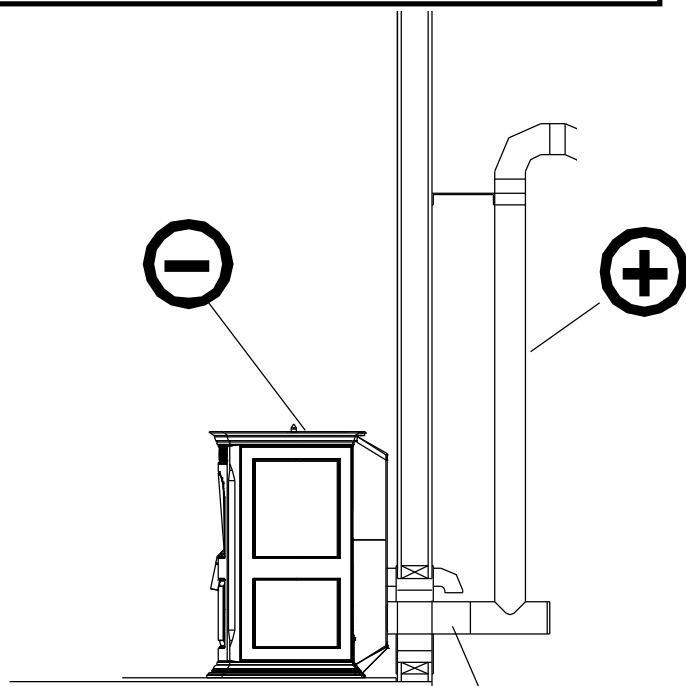

Fig.22

⊕ = Positive static pressure  
 ⊖ = Negative static pressure

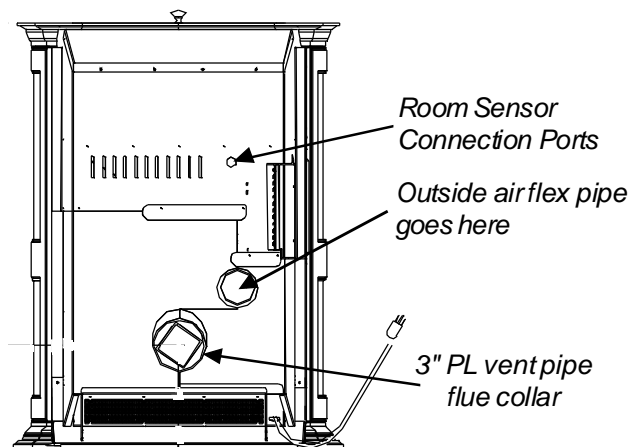

Fig. 23

Flex pipe part#  
 2-00-08543

Inlet Cover part#  
 1-10-08542

Fig. 24

A combustion blower is used to extract the combustion gases from the firebox. This causes a negative pressure in the firebox and a positive pressure in the venting system as shown in fig. 22. The longer the vent pipe and more elbows used in the system, the greater the flow resistance. Because of these facts we recommend using as few elbows as possible and 15 feet or less of vent pipe. The maximum horizontal run should not exceed 48". If more than 15 feet of pipe is needed, the diameter should be increased from 3" to 4" because a larger pipe causes less flow resistance. **Be sure to use approved pellet vent pipe wall and ceiling pass-through fittings to go through combustible walls and ceilings.** Be sure to use a starting collar to attach the venting system to the stove. **The starting collar must be sealed to the stove with high temp silicone caulking.**

## Vent Pipe

Pellet venting pipe (also known as PL vent) is constructed of two layers with air space between the layers. This air space acts as an insulator and reduces the outside surface temperature to allow a clearance to combustibles of only 3 inches. The sections of pipe lock together to form an air tight seal in most cases; however, in some cases a perfect seal is not achieved. For this reason and the fact that the Accentra operates with a positive vent pressure, **we specify that the joints also be sealed with clear silicone.**

## Outside Air

Outside air is optional except in mobile homes and where building codes require. The benefit of outside air is mainly noticed in small, very tight houses.

To install outside air use 2 3/8" I.D. flex pipe part number 2-00-08543. There is a break-away hole on the rear panel which must be removed before connecting the flex pipe. The pipe should be run outside and terminate to the side or below the vent pipe outlet so the flue outlet is more than 12" from the inlet cover. The maximum length run of this pipe is 15 feet. If a longer run is needed, the size must be increased to 3". Inlet cover part number 1-10-08542 should be used to keep birds, rodents, etc. out of pipe.

## HRV

When installing in a house with a Heat Reclaiming Ventilation System (HRV) be sure the system is balanced and is not creating a negative pressure in the house.

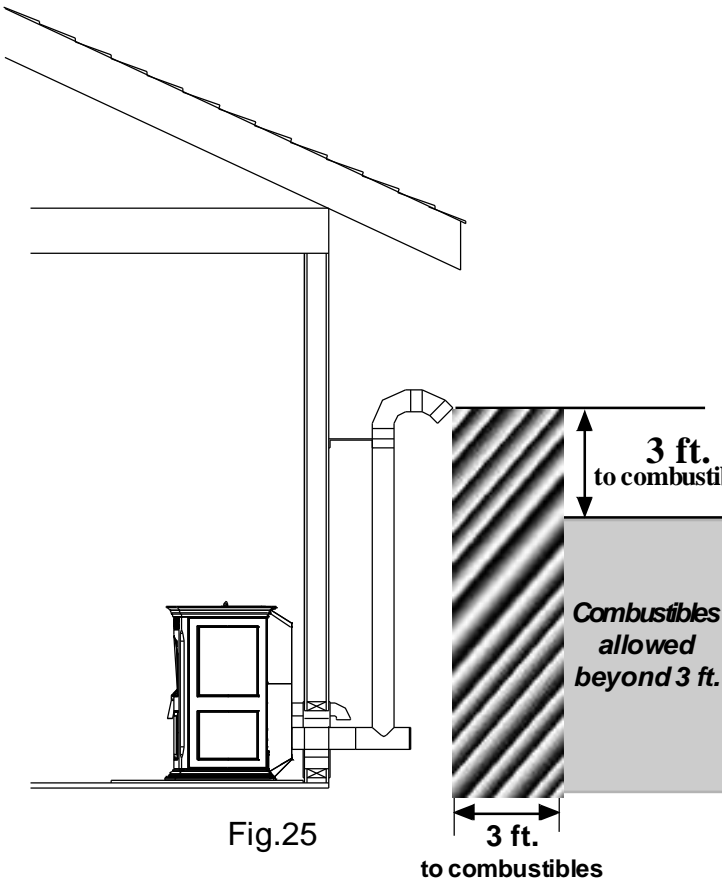

## #1 Preferred method

This method provides excellent venting for normal operation and allows the stove to be installed closest to the wall. Two and a half inches from the wall is safe; however, three inches allows better access to remove the rear panel. The vertical portion of the vent should be three to five feet high. This vertical section will provide natural draft in the event of a power failure. **Note: Do not place joints within wall pass-throughs.**

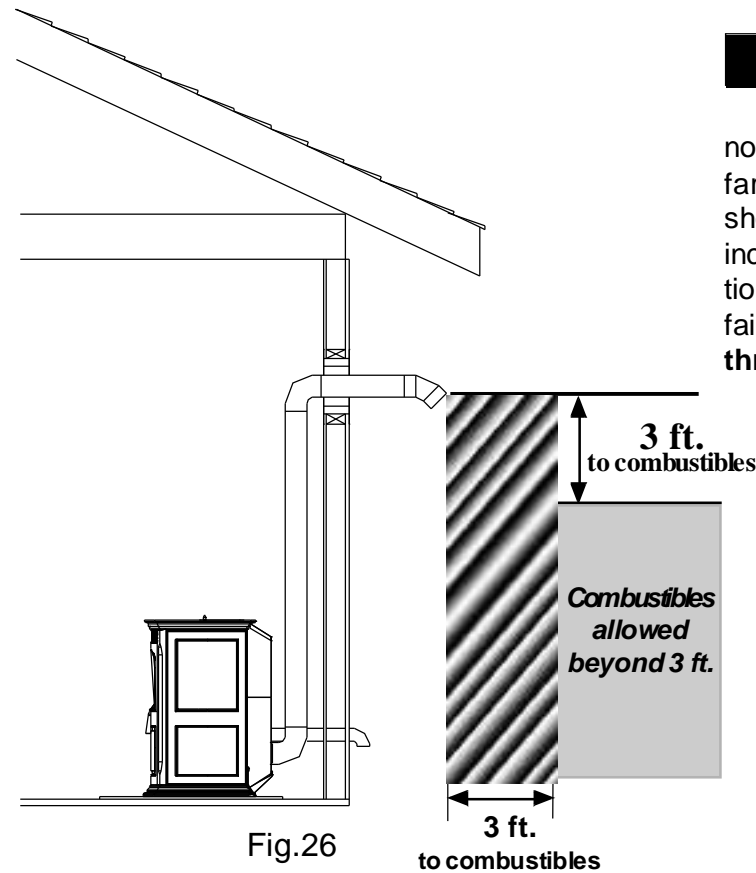

## #2 Preferred method

This method also provides excellent venting for normal operation but requires the stove to be installed farther from the wall. The vertical portion of the vent should be three to five feet high and at least three inches from a combustible wall. This vertical section will provide natural draft in the event of a power failure. **Note: Do not place joints within wall pass-throughs.**

**CAUTION**

**KEEP COMBUSTIBLES (SUCH AS GRASS, LEAVES, ETC.) AT LEAST 3 FEET AWAY FROM THE FLUE OUTLET ON THE OUTSIDE OF THE BUILDING**

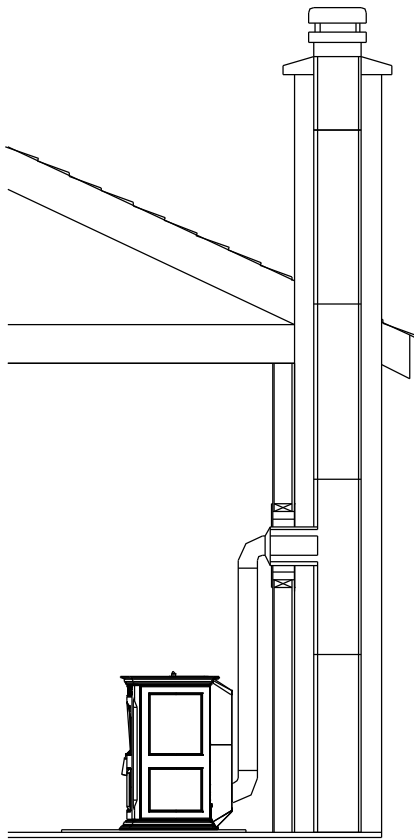

Fig.27

## #4 Installing into an existing chimney (US only)

This method provides excellent venting for normal operation. This method also provides natural draft in the event of a power failure. If the chimney condition is questionable you may want to install a liner as in method #7.

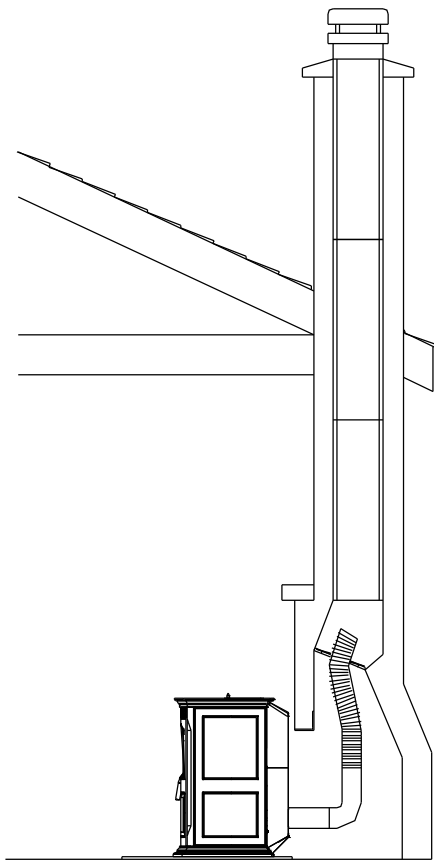

Fig.28

## #5 Installing into an existing fireplace chimney (US only)

This method provides excellent venting for normal operation. This method also provides natural draft in the event of a power failure.

The damper area must be sealed with a steel plate or fiberglass. A cap should be installed on the chimney to keep out rain. If the chimney condition is questionable you may want to install a liner all the way to the top as in Method #6.

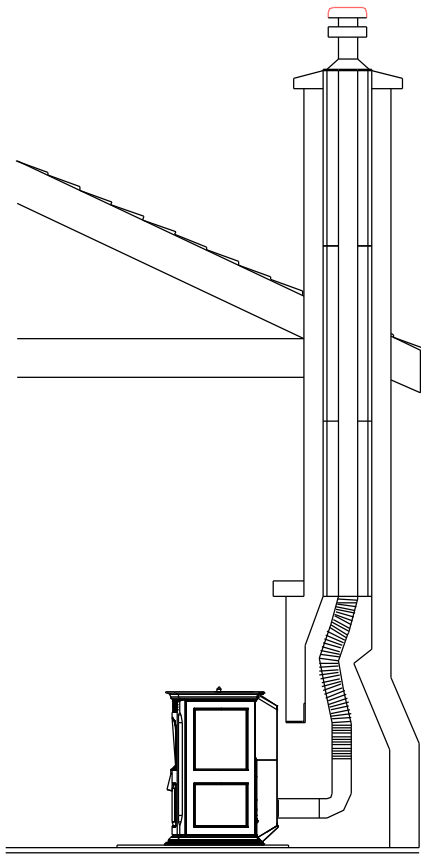

Fig.29

### #6 Installing into an existing fireplace chimney (US and Canada)

This method provides excellent venting for normal operation. This method also provides natural draft in the event of a power failure.

In Canada and some places in the US it is required that the vent pipe extend all the way to the top of the chimney.

In this method a cap should also be installed on the chimney to keep out rain. Be sure to use approved pellet vent pipe fittings. Seal pipe joints with silicone in addition to the sealing system used by the manufacturer. Pipe size should be increased to 4" using this method.

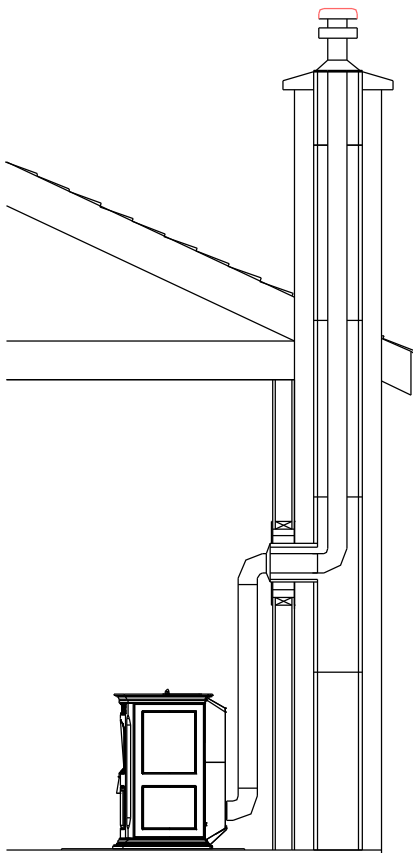

Fig.30

### #7 Installing into an existing chimney (US and Canada)

This method provides excellent venting for normal operation. This method also provides natural draft in the event of a power failure.

In Canada and some places in the US it is required that the vent pipe extend all the way to the top of the chimney. The pipe or liner inside the chimney should be 4" diameter.

In this method a cap should also be installed on the chimney to keep out rain. One disadvantage of this method is that it is harder to clean the vent pipe, therefore, there is a tendency not to do it as often as needed.



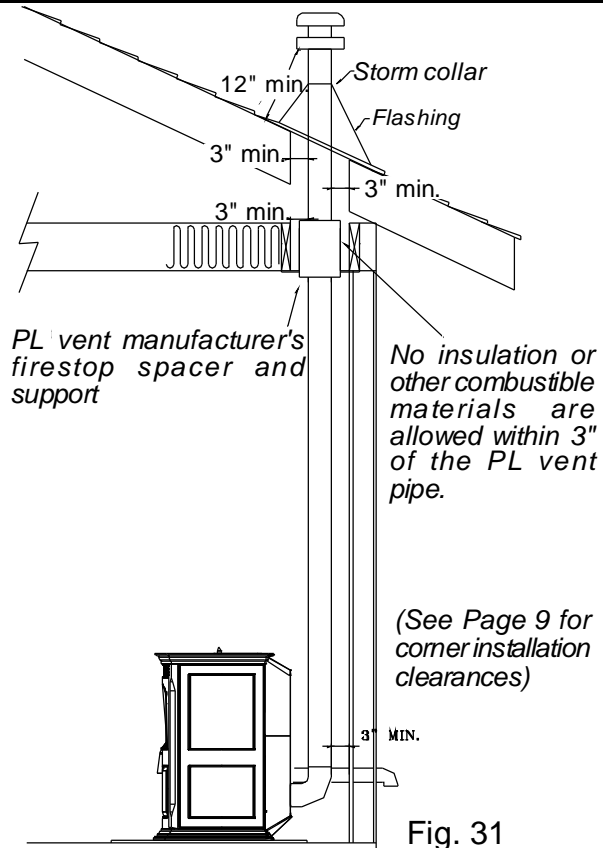

Fig. 31

### Minimum flue vent configuration

It is recommended that outside air be installed with this venting configuration to reduce smoke and creosote smell in the room in the event of power failure.

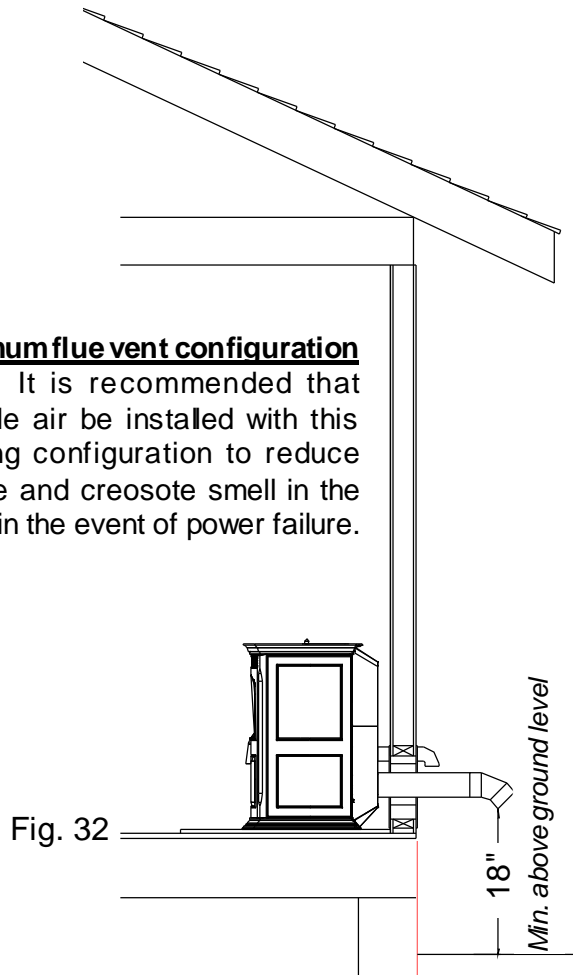
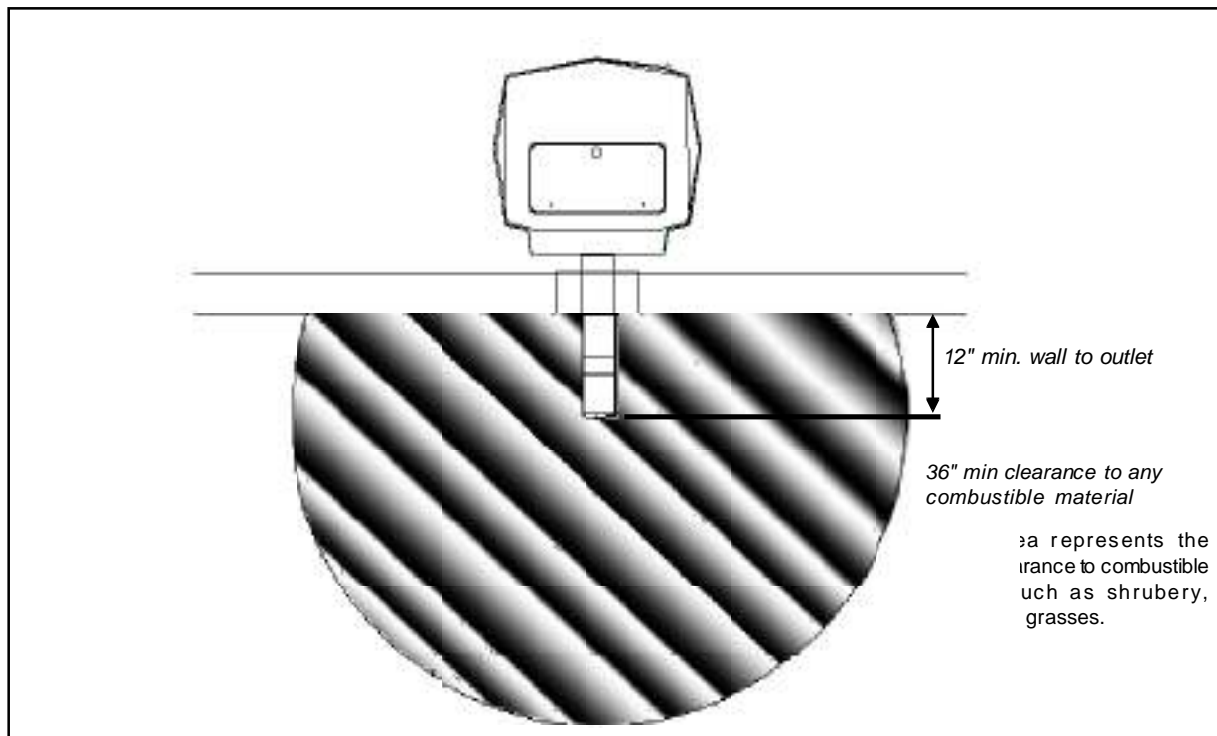

Fig. 32

### #8 Installing through the ceiling vent

Through the ceiling vent, follow PLvent manufacturers recommendations when using wall and ceiling pass through. **Note: Do not place joints within wall pass-throughs.**



## Requirements for Terminating the Venting

**WARNING:** Venting terminals must not be recessed into a wall or siding.

**NOTE:** Only PL vent pipe wall pass-throughs and fire stops should be used when venting through combustible materials.

**NOTE:** Always take into consideration the effect the prevailing wind direction or other wind currents will cause with flyash and/or smoke when placing the termination.

**In addition, the following must be observed:**

A. The clearance above grade must be a minimum of 18".<sup>1</sup>

B. The clearance to a window or door that may be opened must be a minimum of 48" to the side and 48" below the window/door, and 12" above the window/door. <sup>1</sup>

**(with outside air installed, 18")**

C. A 12" clearance to a permanently closed window is recommended to prevent condensation on the window.

D. The vertical clearance to a ventilated soffit located above the terminal within a horizontal distance of 2 feet (60 cm) from the center-line of the terminal must be a minimum of 18".

E. The clearance to an unventilated soffit must be a minimum of 12".

F. The clearance to an outside corner is 11" from center of pipe.

G. The clearance to an inside corner is 12".

H. A vent must not be installed within 3 feet (90 cm) above a gas meter/regulator assembly when measured from the horizontal center-line of the regulator.<sup>1</sup>

I. The clearance to service regulator vent outlet must be a minimum of 6 feet.<sup>1</sup>

J. The clearance to a non-mechanical air supply inlet to the building or the combustion air inlet to any other appliance must be a minimum of 48".<sup>1</sup>

K. The clearance to a mechanical air supply inlet must be a minimum of 10 feet.<sup>1</sup>

**(with outside air installed, 6 feet)**

L. The clearance above a paved sidewalk or a paved driveway located on public property must be a minimum of 7 feet.<sup>1,2</sup>

M. The clearance under a veranda, porch, deck or balcony must be a minimum of 12 inches.<sup>1,3</sup>

**NOTE:** The clearance to vegetation and other exterior combustibles such as mulch is 36" as measured from the center of the outlet or cap. This 36" radius continues to grade or a minimum of 7 feet below the outlet.

<sup>1</sup>Certain Canadian and/or Local codes or regulations may require different clearances.

<sup>2</sup>A vent shall not terminate directly above a sidewalk or paved driveway which is located between two single family dwellings and serves both dwellings.

<sup>3</sup>Only permitted if veranda, porch, deck, or balcony is fully open on a minimum of 2 sides beneath the floor.

**NOTE: Where passage through a wall, or partition of combustible construction is desired, the installation shall conform to CAN/CSA-B365. (if in Canada)**

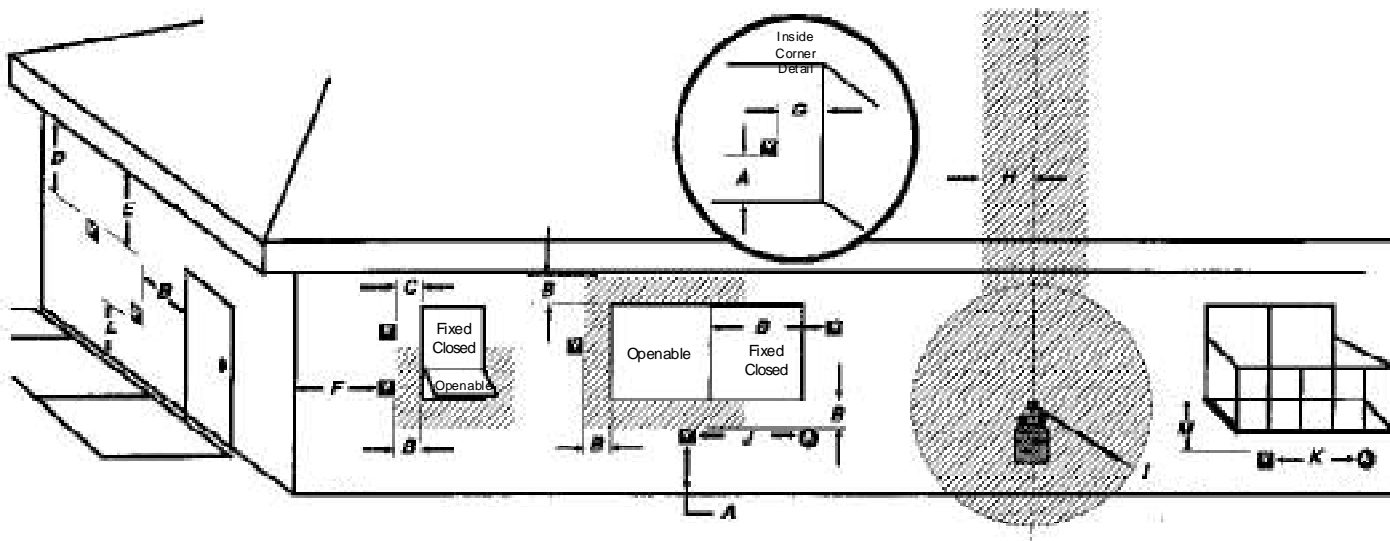

**V** = Vent terminal

**A** = Air supply inlet

 = Area where terminal is not permitted

The unit should be out and cool to clean the door glass. It may not always be possible to allow the unit to cool off before cleaning. Therefore, if the unit is turned to the lowest setting about 1 hour before cleaning, it will make it possible to clean the glass with the unit in operation.

Any glass cleaner with a high amonia content will work the best. Use only non-synthetic cleaning rags such as cotton or paper towels.

**CAUTION: Take care when spraying cleaner on the side surface of the glass. The glass may be hot enough to cause undesirable fumes to fill the area around the unit very rapidly. Gloves and eye protection are recommended.**

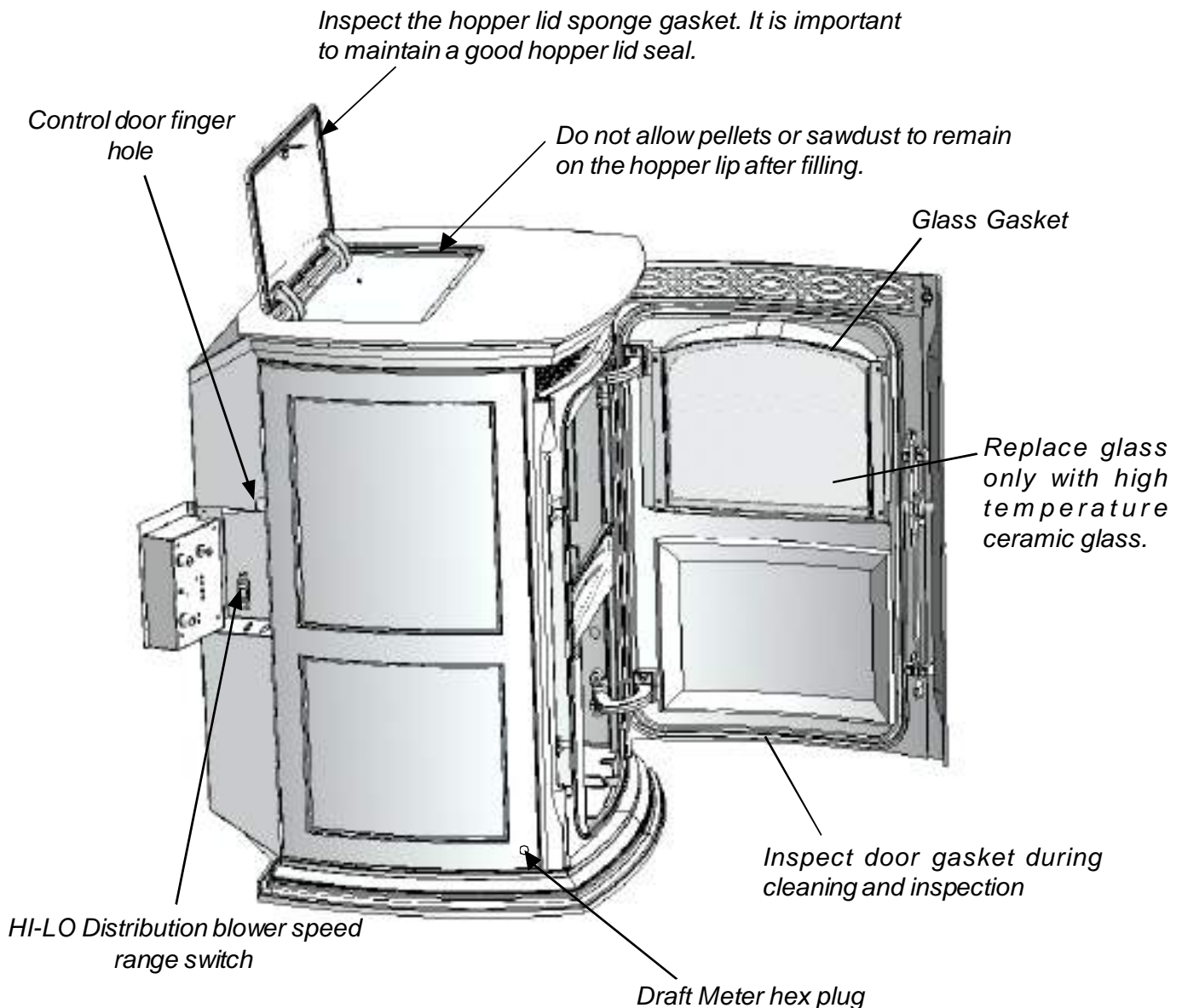

Fig. 34

## Cleaning Internal Components

1. Remove the two heat exchanger covers. See Fig. 35. These covers are made of cast iron and are held into place with a swing latch in the upper right and left corners. See Fig 36. Swing the latch upward far enough to release the top edge of the heat exchanger cover. Tilt the cover forward approximately 2" and lift it upward about 1" to release the bottom edge. The cover can now be taken completely out through the upper door opening. Repeat the process with the second heat exchanger cover.

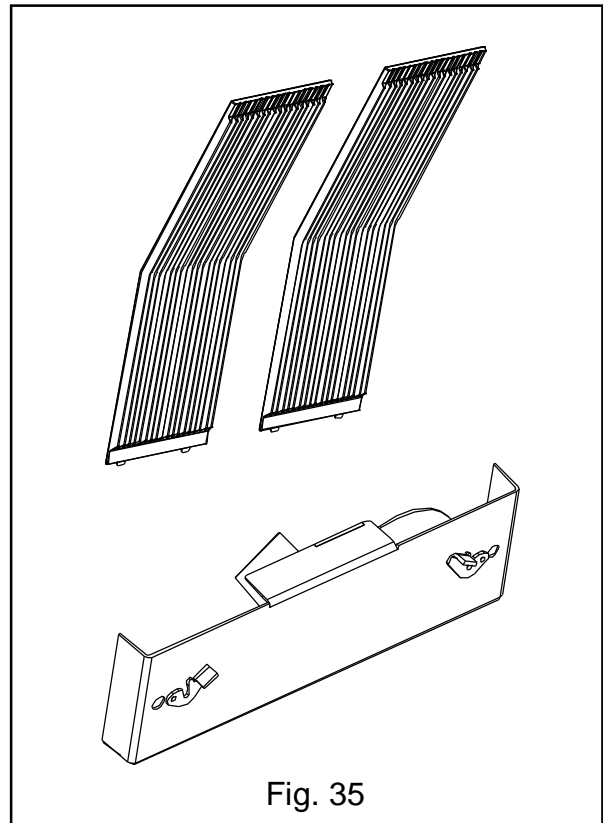

Fig. 35



Possible pellet fines buildup area.

## Feeder Chamber

This chamber may get a buildup of fines from the feeder mechanism movement. This area should be checked and cleaned at least once a year.

### To remove the feeder cover:

- Remove the 5/16" wing nut.
- Slide the cover off of the threaded stud.
- Inspect and clean the inner chamber if necessary. See above picture.
- Reinstall the cover making certain it is centered on the feeder body and tighten as tightly as you can by hand.

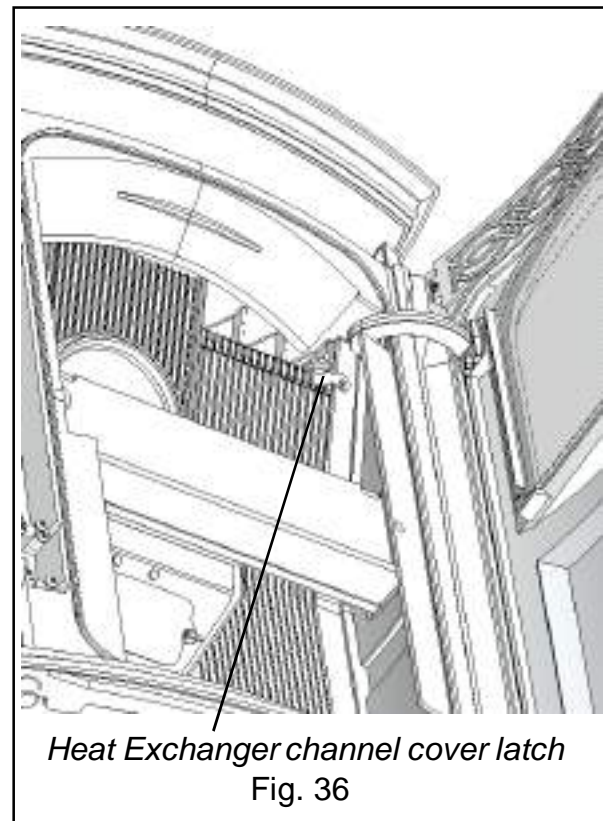

Heat Exchanger channel cover latch

Fig. 36

*(Cleaning Internal Components Cont'd)*

2. Remove the combustion intake assembly. See Fig. 35. The combustion intake assembly is held into place with two swing latches. See Fig. 37. Swing each latch until it hangs down away from the retainer stud. Now the assembly can be taken out by tilting the right side outward first through the lower door opening.

3. The unit's interior is now ready to clean. Use the scraper provided to clean the heat exchanger surfaces. A wire brush or short bristled brush is an excellent cleaning tool. Clean the fan blade and combustion blower fan housing. **NOTE:** Be careful not to bend the fan blade while cleaning. A bent blade will throw the fan blade out of balance. See Fig. 38.

4. With the blower housing open, there is easy access to the flue pipe exiting the rear of the unit. See Fig. 38. Vacuum the flue pipe as far into the pipe as possible. **NOTE:** Be careful while cleaning the flue pipe not to bend the ESP probe. The ESP probe is approximately 8" in the tube and is visible when looking into the tube.

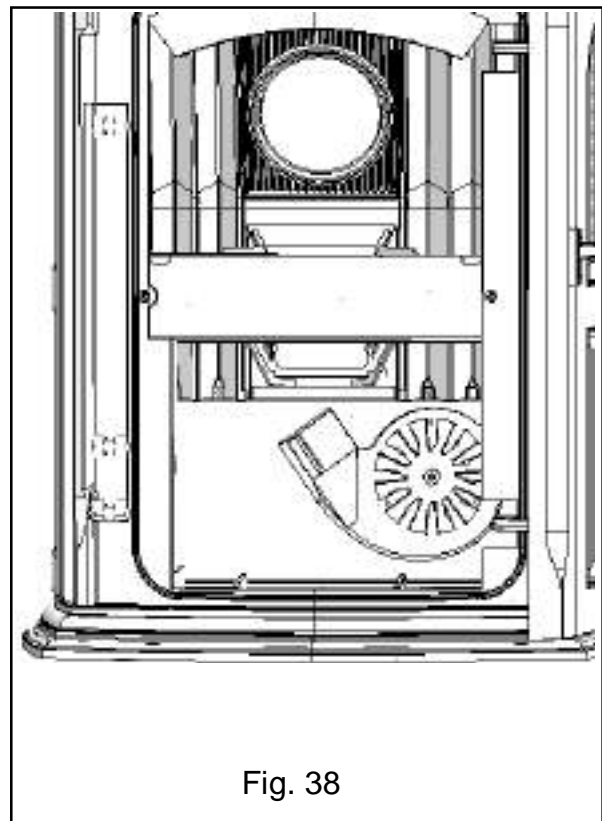
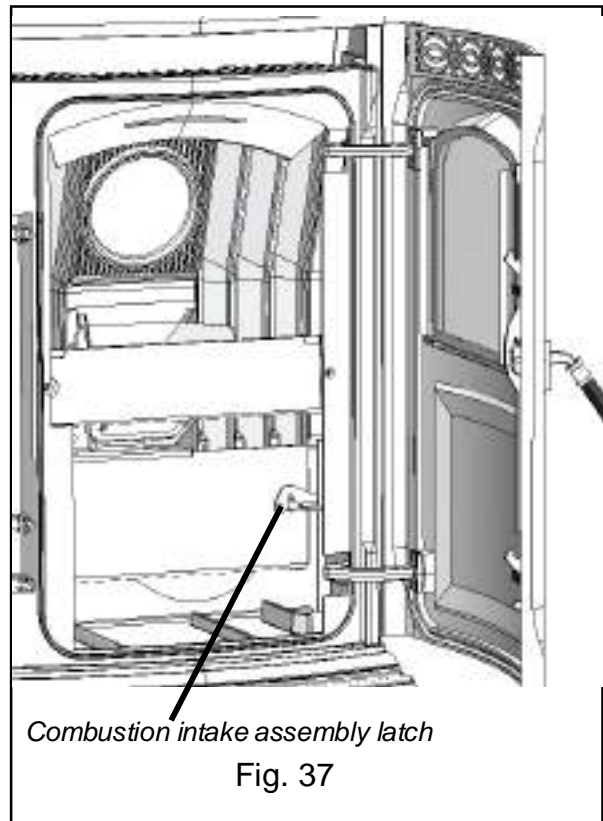

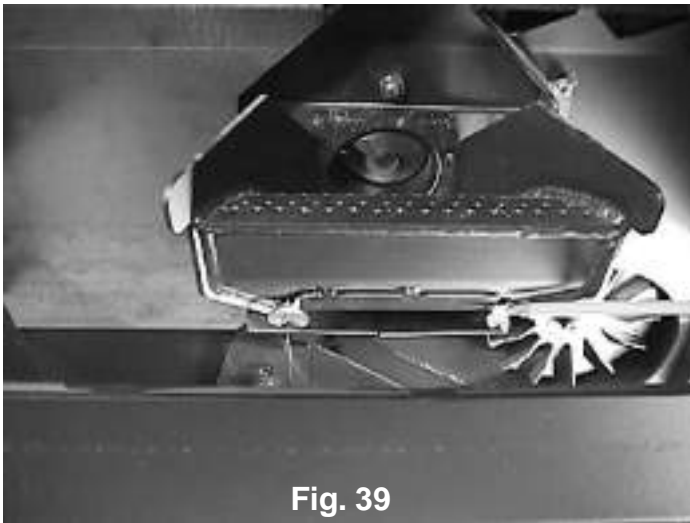

Fig. 39

## Burn Pot Cleaning and Maintenance

1. Scrape the top holed surface and sides of the burn pot down to auger tube.(Fig 39) It is not necessary to completely remove all material from the burn pot. The excess will be pushed out during the next use.
2. Loosen the (2) wing thumb screws on the lower front angle of the burn pot. (Fig. 40)
3. Lift off the clean-out cover (Fig.40) to open the bottom clean-out chamber. (Fig.41)

**DANGER**  
*Disconnect the power to the unit before removing cover.*

4. Clean ash buildup from inside the chamber while cover is off. Use the scraper to tap on the top front edge of the burn pot. This will help knock pieces of ash, loosened by the scraping process, down through the holes. It also helps knock scale off of the ignitor element.

### Figure 41

The ignitor is made to be removable for service by insulated male/female wire connectors. These connections between the hot leads (the wires inside the burn pot) and the cold leads (the wires from the control board) are always pulled to the inside rear of the feeder body. **(Not coiled inside the burn pot.)**

It is very important that these connections are to the inside rear of the feeder body. Also, the extra wire of the ignitor wire service loop must be pulled out through the rear of the feeder and tied up so that it will not be damaged by any moving parts. See page 24.

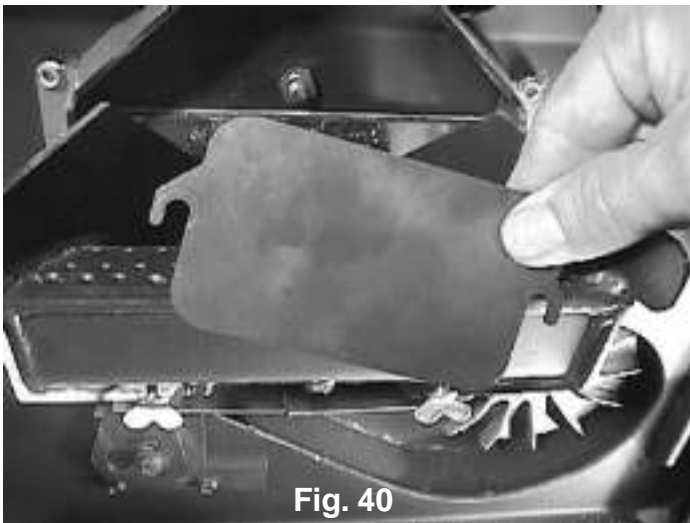

Fig. 40

**DANGER**  
*Disconnect the power to the unit before removing cover.*

**WARNING**  
*Use caution when cleaning burn pot clean-out chamber. Do not damage the high temperature igniter wires.*

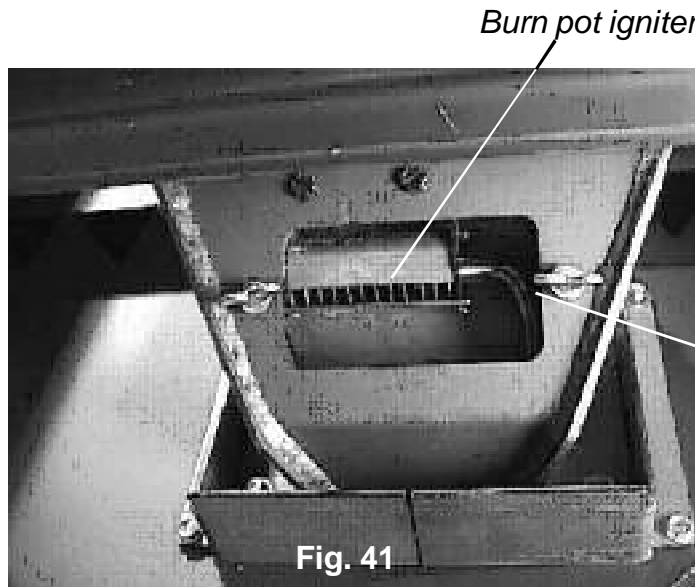

Fig. 41

*Igniter hot lead wires  
(high temperature)*

*Note: The hot lead/cold lead connection must always be pulled to the rear of the feeder body before operation.*

*Viewed from below through the ash pan opening.*

## Accentra Motor & Component Locations

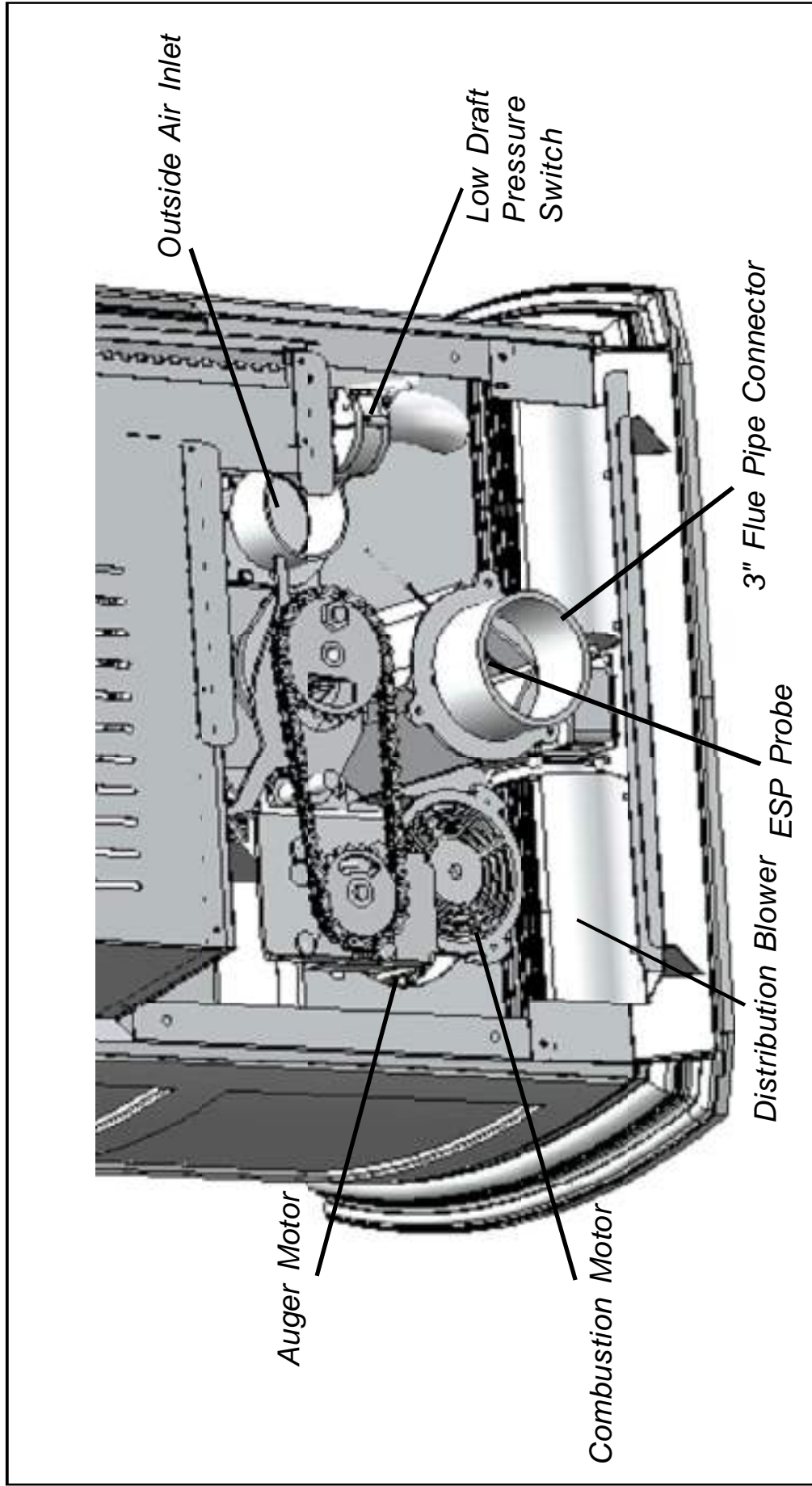

## Accentra Pellet Stove Safety Devices

The **Combustion Motor Fuse** is a thermal overload one-time fuse link within the motor windings. Should the distribution motor fail with the unit operating over 80%, this fuse will protect the other components by melting off at a set temperature. With the fuse blown, the combustion motor will stop. In turn, the feeder motor will not operate and the stove will go out. This may only happen when the unit is on Maximum (#7 on the Temperature Dial, #6 on the Feed Adjuster and Distribution blower not operating). If this fuse does blow, the unit will need service.

The **Control Board/ESP** combination is responsible for all high limit safety control. There are 2 high limits, one normal operation high limit and one backup high limit. The control has an automatic diagnostic circuit that continuously monitors the ESP and Room Sensor for faults. If a fault should occur, the control sends a status alert and at the same time the unit goes down to minimum feed/minimum burn as a safety condition.

The **Low Draft Pressure Switch** is a differential pressure switch that senses the pressure between the firebox and the room. If the pressure becomes too low for proper combustion, the switch opens, turning off the feeder motor and the igniter element. This switch is connected into the AC (high voltage) wires; therefore, the control may show the feeder motor and igniter lights "on" but they are not.

## FEEDER DOES NOT FEED

1. No pellets in hopper.
2. Firebox draft may be too low for low draft pressure switch in feeder circuit to operate. **Check for closed doors**, loose or missing gasket on doors or hopper lid, faulty pressure switch.
3. Feed motor will not run until ESP senses 165 deg. F. Maybe you did not put enough pellets in the burn pot before lighting the fire.
4. Something is restricting flow in the hopper or causing the slide plate to stick.
5. Feed motor has failed.

## PARTIALLY BURNED PELLETS

1. Feed rate too high.
  2. Draft too low. (Check burn pot clean out slide and door gasket).
  3. Burn pot or heat exchanger tubes may need to be cleaned.
  4. Combination of all the above.
  5. #6 status blink: A 6 blink control board status indication is caused by poor or incomplete combustion. The Advance Automatic Ignition circuit board has the ability to track the combustion through feed settings and ESP temperatures. When the control board has calculated poor or incomplete combustion it will shut down the unit as a safety feature. (Poor or incomplete combustion is a contributor of creasote which may cause a chimney fire)
- A 6 blink status may be caused by several things:
1. Blocked or partially blocked flue.
  2. Blocked or partially blocked inlet air.
    - a. backdraft damper on the inlet pipe may be stuck closed.
    - b. if outside air is installed the inlet cover may be blocked.
  3. The air chamber under the burnpot may be filled with fines and small bits of ash.
  4. The holes in the burnpot may be getting filled with ash or carbon buildup.
  5. Combustion blower fan blades may need cleaned.
  6. Combustion intake assembly not properly latched.
  7. No fuel in hopper.

## SMOKE SMELL

Seal the vent pipe joints and connection to stove with silicone.

## FIRE HAS GONE OUT

1. No pellets in hopper.
2. Draft setting is too low.
3. Something is restricting fuel flow.
4. Feed motor or draft motor has failed.
5. Power failure or blown fuse.

## SMOKE IS VISIBLE COMING OUT OF VENT

1. Air-fuel ratio is too rich.
  - A. Feed rate too high.
  - B. Draft too low caused by a gasket leak.

## LOW HEAT OUTPUT

1. Feed rate too low
2. Draft too low because of gasket leak.
3. Poor quality or damp pellets
4. Combination of 1. and 2.

## Helpful Hints

### Cleaning Burn Pot

Whenever your stove is not burning, take the opportunity to scrape the burn pot to remove carbon buildup. A vacuum cleaner is handy to remove the residue. Be sure the stove is cold if you use a vacuum.

Carbon buildup can be scraped loose with the fire burning using the special tool provided with your stove. Scrape the floor and sides of the burn pot. The carbon will be pushed out by the incoming fuel. Always wear gloves to do this.

### Removing Ashes

Turn the Temp Dial to number 1 approximately 30 minutes before removing ashes. This will result in a cooler stove and ash pan.

Maximum Feed Adjuster settings are not needed in most cases. Operating in the normal range (#4) is recommended when maximum heat output is not required. The ESP probe prevents the stove from being over-fired.

Keep the stove free of dust and dirt.

## Fuel

Pellet fuels are put into 3 categories in terms of ash content. Premium at 1% or less, Standard at 3% or less and all others at 3% or more.

The Accentra is capable of burning all 3 categories of pellets due to a patented feeder and burn pot system.

It should be noted, however, that higher ash content will require more frequent ash removal and may provide less BTU's per pound. Normally, standard and high ash pellets cost less than premium pellets and can be cost effective when burned in the Accentra.

The moisture content must not exceed 8%. Higher moisture will rob BTU's and may not burn properly.



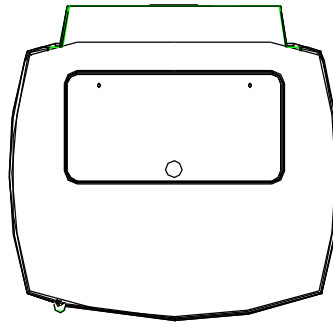
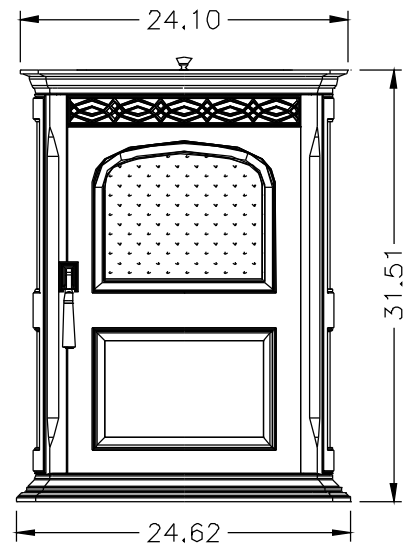
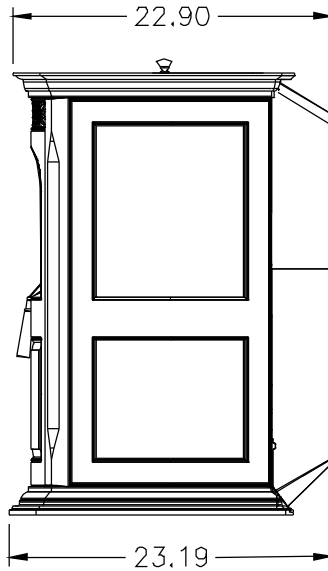
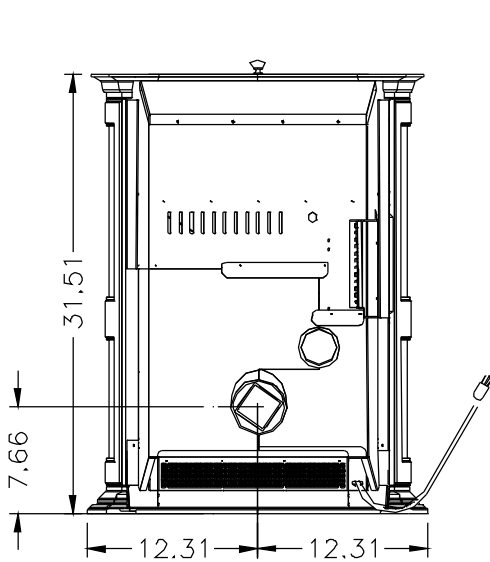

<b>Weight</b>	<b>350 lbs.</b>
<b>Blower</b>	<b>150 cfm</b>
<b>Hopper Capacity</b>	<b>50 lbs.</b>
<b>Fuel</b>	<b>Wood Pellets</b>
<b>Outside Air Size</b>	<b>2 3/8 inches</b>
<b>Fuse Rating</b>	<b>5 amp</b>
<b>BTU Range</b>	<b>0 to 40,000</b>
<b>Feed Rate</b>	<b>.75 lbs./hr. on minimum(on maintenance)</b> <b>5 lbs./ hr. on maximum</b>
<b>Flue Size</b>	<b>3 inch Pellet Vent Pipe</b>
<b>Maximum Wattage</b>	<b>440 Watts (Start cycle and test)</b>
<b>Start Cycle Wattage</b>	<b>340 Watts</b>
<b>Normal Run Wattage</b>	<b>255 Watts</b>

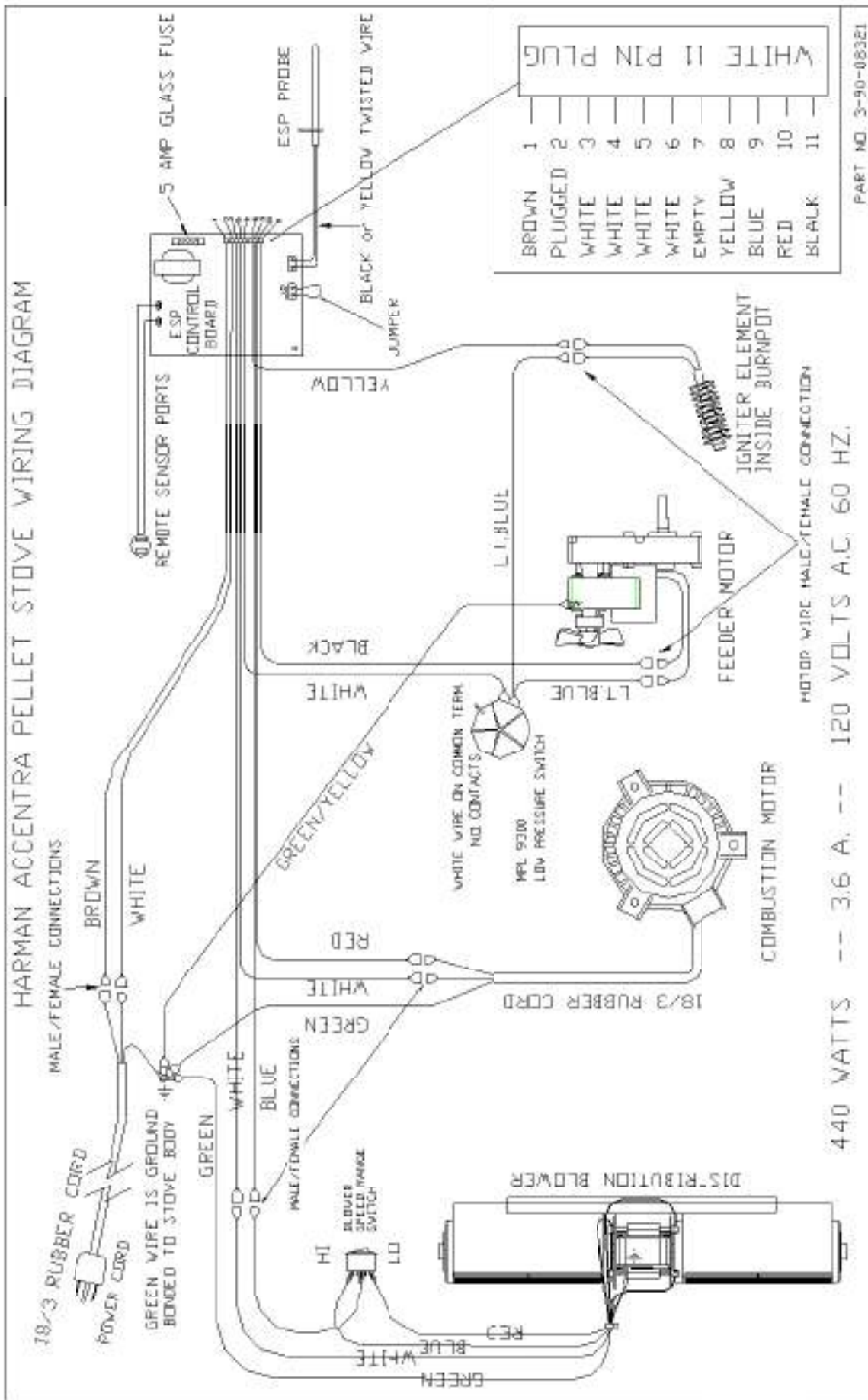



<u>Description</u>	<u>Part Number</u>
Hopper Lid Gasket	3-44-247101
Ignitor Element Assembly	1-10-06620
Wiring Harness	3-20-08727
Burn Pot Weldment	1-10-08736
Right Feeder Shield w/sound proof	1-10-247142
Left Feeder Shield w/sound proof	1-10-247141
Heat Exchanger Cover (2)	3-00-247105
Arrow Scraper	2-00-773850
Flame Guide	3-00-08534
Gear Motor	3-20-08752
Thermister Probe	3-20-00744
Room Sensor	3-20-00906
Circuit Board G4220G V5.0	3-20-04220
Feeder Switch Jumper	3-20-08750
3" White CCW Fan Blade(auger motor)	3-20-08789
Differential Switch	3-20-9301
5" Single Paddle Combustion Fan Blade	3-20-40985
Combustion Blower	3-21-08639
Distribution Blower	3-21-29045
Tailpipe Insulator	3-44-247168
White/Black Control Knob (3)	3-31-00968
Control Knob Shaft (3)	3-31-00982
Front Glass w/gasket	1-10-247127
Hopper Lid Knob	3-43-02000
Burn Pot Gasket (2)	3-44-00409
Tailpipe Gasket (2)	3-44-06179
Wood Handle	3-40-00247
Wiring Diagram	3-90-08321
Control Panel Sticker	3-90-247155
Owner's Manual	3-90-08326
Hopper Lid Label	3-90-08416
Rocker Switch	3-20-07625
Combustion Manifold Assembly	1-10-247126
Ash Pan Assembly	1-10-247160
Hopper Lid Glass	3-40-247100
Ball Spring Plunger (2)	3-31-73765
<b><u>Options:</u></b> Outside Air Assembly	1-10-08542
3' Flex Pipe	2-00-08543
Cast Iron Hearth Pad	1-00-02471-?(color)
45 Degree Tailpipe Weldment	1-10-247129
5"Double Paddle High Altitude Fan Blade	3-20-502221

See page 27 for  
Feeder Part Numbers

## **HARMAN GOLD WARRANTY** **6 YEAR TRANSFERABLE LIMITED** **WARRANTY (Residential)** **1 YEAR LIMITED WARRANTY (Commercial)**



Harman Stove Company warrants its products to be free from defects in material or workmanship, in normal use and service, for a period of 6 years from the date of sales invoice and for mechanical and electrical failures, in normal use and service, for a period of 3 years from the date of sales invoice.

If defective in material or workmanship, during the warranty period, Harman Stove Company will, at its option, repair or replace the product as described below.

The warranty above constitutes the entire warranty with respect to Harman Stove Company products. HARMAN STOVE COMPANY MAKES NO OTHER WARRANTY, EXPRESSED OR IMPLIED, INCLUDING "ANY" WARRANTY OF MERCHANTABILITY, OR WARRANTY OF FITNESS FOR A PARTICULAR PURPOSE. No employee, agent, dealer, or other person is authorized to give any warranty on behalf of Harman Stove Company. This warranty does not apply if the product has been altered in any way after leaving the factory. Harman Stove Company and its agents assume no liability for "resultant damages of any kind" arising from the use of its products. In addition, the manufacturer and its warranty administrator shall be held free and harmless from liability from damage to property related to the operation, proper or improper, of the equipment.

THERE ARE NO WARRANTIES WHICH EXTEND BEYOND THE DESCRIPTION ON THE FACE HEREOF. THESE WARRANTIES APPLY only if the device is installed and operated as recommended in the user's manual.

THESE WARRANTIES WILL NOT APPLY if abuse, accident, improper installation, negligence, or use beyond rated capacity causes damage.

HOW TO MAKE A CLAIM - Any claim under this warranty should be made to the dealer from whom this appliance was purchased. Then contact is made with manufacturer, giving the model and serial numbers, the date of purchase, your dealer's name and address, plus a simple explanation of the nature of the defect. Extra costs such as mileage and overtime are not covered. Nuisance calls are not covered by these warranties.

THIS WARRANTY IS LIMITED TO DEFECTIVE PARTS-REPAIR AND/OR REPLACEMENT AT HARMAN STOVE COMPANY'S OPTION AND EXCLUDES ANY INCIDENTAL AND CONSEQUENTIAL DAMAGES CONNECTED THEREWITH.

WARRANTY EXCLUSIONS: Failure due, but not limited to, fire, lightning, acts of God, power failures and/or surges, rust, corrosion and venting problems are not covered. Damage and/or repairs including but not limited to; remote controls, filters, fuses, knobs, glass, ceramic brick panels, ceramic fiber afterburners, door packing, tile, ceramic log sets, paint, batteries or battery back-up and related duct work are not covered. Also excluded from this warranty are consumable or normal wear items including but not limited to; flame guides, grates, coal bars, afterburner hoods, fire brick, gaskets. Additional exclusions for corn stoves are burnpot housing weldment, burnpot grate weldment (pellet or corn), burnpot front plate (pellet or corn), burnpot front plate lock, corn auger extension, ceramic insert, and ceramic insert plate. Additional or unusual utility bills incurred due to any malfunction or defect in equipment and the labor cost of gaining access to or removal of a unit that requires special tools or equipment are not covered. Maintenance needed to keep the stove in "good operating condition" is not covered. This includes, but is not limited to, cleaning, adjustment of customer controls and customer education. Labor, materials, expenses and/or equipment needed to comply with law and/or regulations set forth by any governmental agencies are not covered.

This Warranty provides specific legal rights and the consumer may have other rights that vary from state to state.

In the event of change in ownership, the remaining portion of this warranty may be transferred to the new owner by sending the new owner information to the Harman Stove Company.

PLEASE READ THE LITERATURE BY THE MANUFACTURER FOR THE VARIOUS ACCESSORY DEVICES. THE MANUFACTURER WARRANTS THESE ACCESSORY DEVICES, NOT HARMAN STOVE COMPANY OR THEIR WARRANTY ADMINISTRATOR. FURTHERMORE, THESE ACCESSORY DEVICES MUST BE INSTALLED AND USED ACCORDING TO THE RECOMMENDATIONS OF THE MANUFACTURER.

REMEDIES - The remedies set forth herein are exclusive and the liability of seller with respect to any contract or sale or anything done in connection therewith, whether in Contract, in tort, under any warranty, or otherwise, shall not, except as herein expressly provided, exceed the price of the equipment or part of which such liability is based.

CLARIFY - The above represents the complete warranty, which is given in connection with stoves, manufactured by Harman Stove Company. No other commitments, verbal or otherwise, shall apply except by a written addendum to this warranty.